

Conversion Guide

Series 05-31 and 05-32 To Series 35-65
24 VAC Hot Surface Ignition Control

parts4heating
800-536-1582 Fax: 866-448-9304
info@parts4heating.com



The Fenwal 05-31 and 05-32 Series analog-based hot surface ignition controls are being replaced by the Fenwal 35-65 Series microprocessor-based hot surface ignition controls. The 35-65 Series is a modern design with a proven field history and offers significant advantages over its analog predecessors.

35-65 Series Advantages:

- Precise ignition and purge timings
- LED diagnostics for quick and accurate troubleshooting
- Flame current test pins for added troubleshooting assistance
- Improved flame sensitivity
- Software based customization for ignition and purge timings

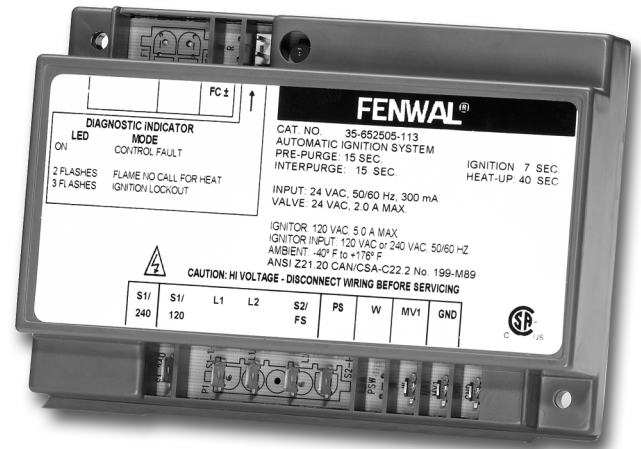

This guide includes:

- Agency approval comparisons
- Terminal designation and size comparison
- Control wiring comparison
- Dimension (footprint) comparison
- Conversion list for most popular controls

Conversion Notes: (Installation should be performed by trained professionals only)

- 1) The 35-65 Series footprint is larger than the 05-31 and 05-32 models. Modifications may have to be made to the appliance to accommodate the 1.5-inch by 0.75-inch (approximate) increase in length and width. Refer to Figures 3 and 4 for dimension comparisons.
- 2) **CAUTION:** Before installation refer to the Terminal Designation Comparison Chart (Table 2) and the wiring diagrams (Figures 1 and 2) to become familiar with the changes in the terminology and connections between the 05-31 or 05-32 Series and the 35-65 Series.
- 3) **CAUTION:** Note that both 24VAC and 120VAC are required for the system. Interrupt both power supplies before proceeding with wiring.
- 4) **CAUTION:** Do not apply power to the module until all wiring is connected and ensure that the system is

properly grounded. Refer to the 35-65 Installation Instructions.

- 5) **CAUTION:** System must be checked after installation and before gas supply is turned on. Refer to the 35-65 Installation Instructions.
- 6) The 35-65 Series does not have a valve ground (MV2). Therefore if the MV2 is used on the 05-31 or 05-32 Series, the wire should be connected to the GND terminal (24VAC ground) on the 35-65 Series.
- 7) The 35-65 Series does not have an alarm circuit (NC) because the 35-65 Series provides an on-board diagnostics LED. If the NC connection is required, a separate 24VAC relay should be connected to the 35-65 model's MV1 and GND terminals. Use the NC contacts of the relay to replace the 05-31 or 05-32 NC output function.

Table 1 - Agency Comparison

Agency Approval	05-31	05-32	35-65
UL 372	Not applicable after 1997	Not applicable after 1997	Pending
CSA: ANSI Z21.20, CAN/CSA C22.2 No.199-M89	Approved	Approved	Approved
FM: Ignition Device and Flame Safeguard	Not Approved	Not Approved	Select models

Table 2 - Terminal Designation and Size Comparison

Description	Terminal Designation			Quick Connect Terminal		
	05-31	05-32	35-65	05-31	05-32	35-65
Thermostat Input	TH	TH	W	1/4 inch	1/4 inch	1/4 inch
System Ground	GND	GND	GND	3/16 inch	3/16 inch	3/16 inch
Valve Power	MV1	MV1	MV1	3/16 inch	3/16 inch	3/16 inch
Valve Common	MV2	MV2	Note 6	3/16 inch	3/16 inch	Note 6
120 VAC HOT *	L1	L1	L1	1/4 inch*	1/4 inch*	1/4 inch*
120 VAC Neutral	L2	L2	L2	1/4 inch	1/4 inch	1/4 inch
Ignitor *	S1	S1	S1	1/4 inch*	1/4 inch*	1/4 inch*
Ignitor/Remote Flame Sensor	FS/S2	FS/S2	S2	1/4 inch	1/4 inch	1/4 inch
Normally Closed Alarm Circuit	NC	NC	Note 7	1/4 inch	1/4 inch	Note 7
Flame Current Test Pins	None	None	FC1, FC2			PIN **

* All models use the same AMP MATE-N-LOK connector for L1 and S1 connections if the control has that option

** Flame Current test pins are either AMP p/n 640383-2 or Molex p/n 26-60-2020

05-31 and 05-32 to 35-65 Wiring Comparison

Local Sense

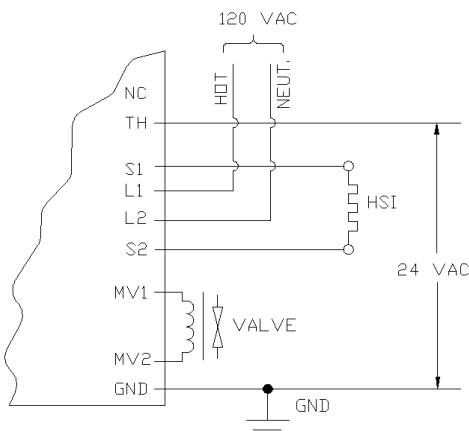

Figure 1a: 05-31 and 05-32 wiring diagram

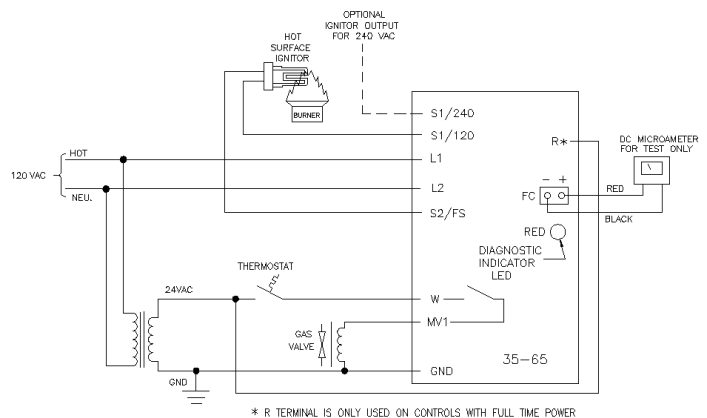

Figure 1b: 35-65 wiring diagram

Remote Sense

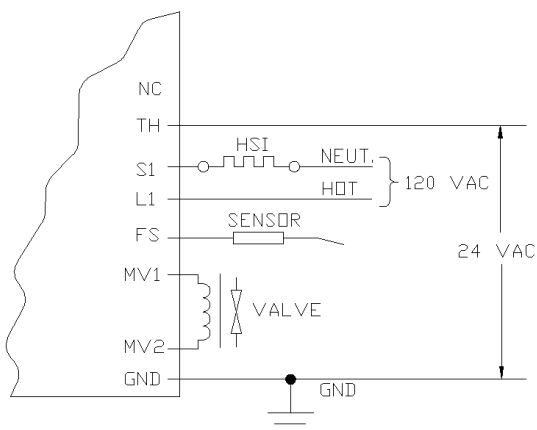

Figure 2a: 05-31 and 05-32 wiring diagram

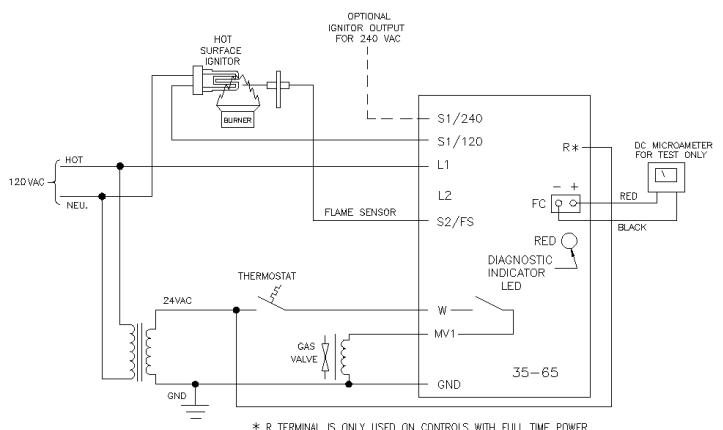

Figure 2b: 35-65 wiring diagram

05-31 and 05-32 to 35-65 Dimension Comparison

05-31 and 05-32

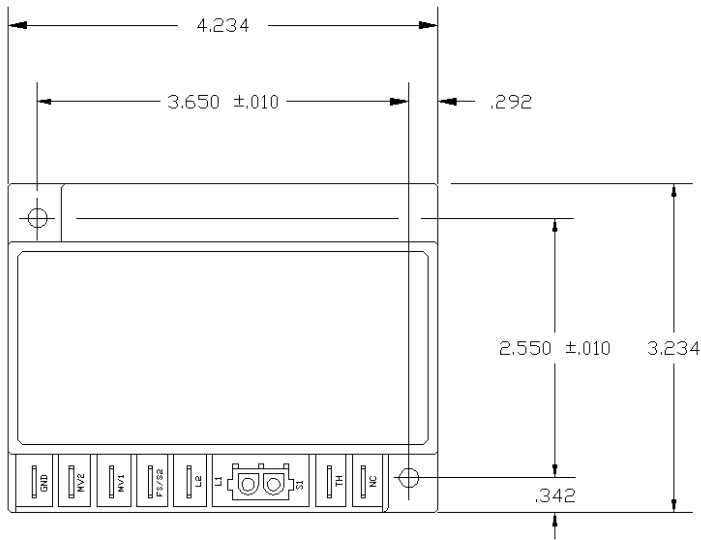

Figure 3a: 05-31 and 05-32 dimensions (front)

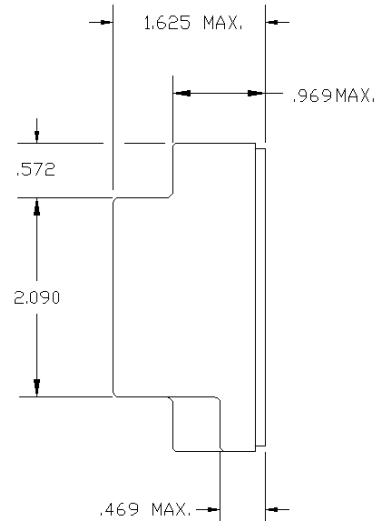

Figure 3b: 05-31 and 05-32 dimensions (side)

35-65

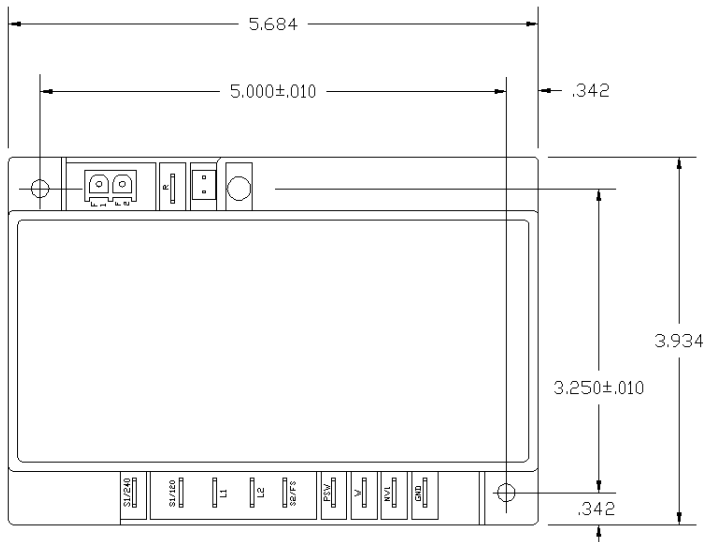

Figure 4a: 35-65 dimensions (front)

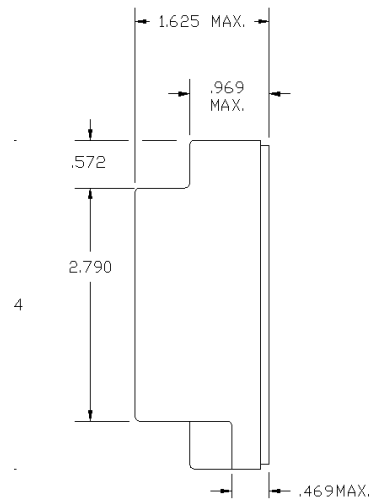

Figure 4b: 35-65 dimensions (side)

05-31 and 05-32 to 35-65 Conversion Chart

Part Number	Replacement	Notes
05-316225-051	35-655500-001	LARGER REPLACEMENT
05-316225-052	35-655500-001	LARGER REPLACEMENT
05-316225-053	35-655500-003	LARGER REPLACEMENT
05-316225-054	35-655500-005	LARGER REPLACEMENT
05-316225-151	35-655500-105	LARGER REPLACEMENT
05-316226-051	35-655520-001	LARGER REPLACEMENT
05-316226-052	35-655520-001	LARGER REPLACEMENT
05-316226-053	35-655520-003	LARGER REPLACEMENT
05-316226-054	35-655520-005	LARGER REPLACEMENT
05-316226-151	35-655520-101	LARGER REPLACEMENT
05-316226-153	35-655520-103	LARGER REPLACEMENT
05-316226-154	35-655520-105	LARGER REPLACEMENT
05-316226-155	35-655520-107	LARGER REPLACEMENT
05-316265-051	35-655505-011	LARGER REPLACEMENT
05-316265-052	35-655505-011	LARGER REPLACEMENT
05-316265-053	35-655505-013	LARGER REPLACEMENT
05-316265-054	35-655505-015	LARGER REPLACEMENT
05-316265-153	35-655505-113	LARGER REPLACEMENT
05-316266-051	35-655525-011	LARGER REPLACEMENT, 4 SECOND TFI INSTEAD OF 3 SECOND TFI
05-316266-052	35-655525-011	LARGER REPLACEMENT, 4 SECOND TFI INSTEAD OF 3 SECOND TFI
05-316266-053	35-655525-013	LARGER REPLACEMENT
05-316266-054	35-655525-015	LARGER REPLACEMENT
05-316266-055	35-655525-017	LARGER REPLACEMENT
05-316266-151	35-655525-111	LARGER REPLACEMENT
05-316266-152	35-655525-111	LARGER REPLACEMENT
05-316266-153	35-655525-113	LARGER REPLACEMENT
05-319000-051	TO BE ASSIGNED	LARGER REPLACEMENT, ALSO REPLACES 05-219003-10X
05-319000-053	TO BE ASSIGNED	LARGER REPLACEMENT, ALSO REPLACES 05-219003-10X
05-319000-251	TO BE ASSIGNED	LARGER REPLACEMENT, ALSO REPLACES 05-219003-10X
05-319000-252	OBSOLETE	NO REPLACEMENT REQUIRES WIRES THROUGH BACK OF BOARD
05-319003-051	TO BE ASSIGNED	LARGER REPLACEMENT, COVER AND BASE NOT RIVETED
05-319004-051	TO BE ASSIGNED	LARGER REPLACEMENT, COVER AND BASE NOT RIVETED
05-319005-052	TO BE ASSIGNED	LARGER REPLACEMENT
05-326225-053	35-655600-003	LARGER REPLACEMENT
05-326225-054	35-655600-005	LARGER REPLACEMENT
05-326225-055	35-655600-007	LARGER REPLACEMENT
05-326226-052	35-655620-001	LARGER REPLACEMENT
05-326226-053	35-655620-003	LARGER REPLACEMENT
05-326265-050	OBSOLETE	NO REPLACEMENT, REQUIRES 1.5 TRIAL FOR IGNITION
05-326265-051	35-655605-001	LARGER REPLACEMENT
05-326265-052	35-655605-001	LARGER REPLACEMENT
05-326265-053	35-655605-003	LARGER REPLACEMENT
05-326265-054	35-655605-005	LARGER REPLACEMENT
05-326265-055	35-655605-007	LARGER REPLACEMENT
05-326266-053	35-655625-003	LARGER REPLACEMENT
05-326266-054	35-655625-005	LARGER REPLACEMENT
05-326266-055	35-655625-007	LARGER REPLACEMENT
05-329000-055	TO BE ASSIGNED	TRIANCO HEATMAKER, SPECIAL TERMINALS
05-329001-052	TO BE ASSIGNED	LARGER REPLACEMENT, ALSO REPLACES EVCON 1474-002
05-329002-053	35-655800-003	LARGER REPLACEMENT, ALSO REPLACEMENT KIT FOR 05-21 AND 05-24 SERIES
05-329003-053	35-655801-013	LARGER REPLACEMENT, ALSO REPLACEMENT KIT FOR 05-21 AND 05-24 SERIES
05-329004-055	35-655802-007	LARGER REPLACEMENT, ALSO REPLACEMENT KIT FOR 05-21 AND 05-24 SERIES



KIDDE-FENWAL, INC.
 400 MAIN STREET, ASHLAND, MA 01721
 TEL: (508) 881-2000 FAX: (508) 881-6729
www.fenwalcontrols.com

These instructions do not purport to cover all the details or variations in the equipment described, nor do they provide for every possible contingency to be met in connection with installation, operation and maintenance. All specifications subject to change without notice. Should further information be desired or should particular problems arise which are not covered sufficiently for the purchaser's purposes, the matter should be referred to KIDDE-FENWAL, Inc., Ashland, MA.

© 2003 Kidde-Fenwal Inc. Printed in the USA

TAG 2/20/03

P/N CG 05-33 & 05-32 to 35-65