

Conversion Guide

Series 05-33 To Series 35-65 / 35-66
24 VAC Hot Surface Ignition Control



The Fenwal 05-33 Series analog-based hot surface ignition controls are being replaced by the Fenwal 35-65 / 35-66 Series microprocessor-based hot surface ignition controls. The 35-65 / 35-66 Series are a modern design with a proven field history and offer significant advantages over its analog predecessors.

35-65 / 35-66 Series Advantages:

- Precise ignition and purge timings
- LED diagnostics for quick and accurate troubleshooting
- Flame current test pins for added troubleshooting assistance
- Improved flame sensitivity
- Software based customization for ignition and purge timings
- Proven pressure switch feature



This guide includes:

- Agency approval comparisons
- Terminal designation and size comparison
- Control wiring comparison
- Dimension (footprint) comparison
- Conversion list for most popular controls

Conversion Notes:

- 1) **CAUTION:** Before installation refer to the Terminal Designation Comparison Chart (Table 2) and the wiring diagrams (Figures 1, 2, 3 and 4) to become familiar with the changes in the terminology and connections between the 05-33 Series and the 35-65 / 35-66 Series.
- 2) **CAUTION:** Note that both 24VAC and 120/240VAC are required for the system. Interrupt both power supplies before proceeding with wiring.
- 3) **CAUTION:** Do not apply power to the module until all wiring is connected and ensure that the system is properly grounded. Refer to the 35-65 / 35-66 Installation Instructions.
- 4) **CAUTION:** System must be checked after installation and before gas supply is turned on. Refer to the 35-65 / 35-66 Installation Instructions.
- 5) **CAUTION:** The position of the 120VAC and 240VAC terminals on the 35-65 / 35-66 Series are reversed from the 05-33 Series, refer to the 35-65 / 35-66 Installation Instructions.
- 6) **For converting from the 05-33 with the blower option only:** The wire that was connected to the TH terminal on the 05-33 should be connected to the PSW terminal (pressure switch) on the new 35-66. The wire that connected to the IND terminal on the 05-33 should be connected to the W (thermostat) terminal on the new 35-66.
- 7) The 35-65 / 35-66 Series footprints are the same as the 05-33 models. Modifications will not be required to the appliance to accommodate the new control. Refer to Figures 5 and 6 for dimension comparisons

Table 1 - Agency Comparison

Agency Approval	05-33	35-65	35-66
UL 372	Approved	Pending	Pending
CSA: ANSI Z21.2, CAN/CSA C22.2 No.199-M89	Approved	Approved	Approved
FM: Ignition Device and Flame Safeguard	Not Approved	Select models	Select models

Table 2 - Terminal Designation and Size Comparison

Description	Terminal Designation			Quick Connect Terminal	
	05-33	05-33 with inducer	35-65 / 35-66	05-33	35-65 / 35-66
Thermostat Input	TH	IND (Note 6)	W	1/4 inch	1/4 inch
System Ground	GND	GND	GND	3/16 inch	3/16 inch
Valve Power	VAL (MV1)	VAL (MV1)	MV1	3/16 inch	3/16 inch
120 VAC Input (hot) *	L1	L1	L1	1/4 inch*	1/4 inch
120 VAC Neutral	L2	L2	L2	1/4 inch	1/4 inch
Ignitor	IGN/120 or IGN/240	IGN/120 or IGN/240	S1/120 or S1/240	1/4 inch*	1/4 inch
Ignitor/Remote Flame Sensor	IGN	IGN	S2	1/4 inch	1/4 inch
Pressure Switch Input	None	TH (Note 6)	PSW (35-66 only)	1/4 inch	1/4 inch
24VAC Full Time Power	24V	24V	R	1/4 inch	1/4 inch
Inducer (Blower) Power	F1	F1	F1	1/4 inch	1/4 inch
Inducer (Blower) Neutral	F2	F2	F2	1/4 inch	1/4 inch
Flame Current Test Pins			FC1, FC2		PIN**

* All models use the same AMP MATE-N-LOK connector for connections if the control has that option

** Flame Current test pins are either AMP p/n 640383-2 or Molex p/n 26-60-2020

05-33 to 35-65 Wiring Comparison

Local Sense

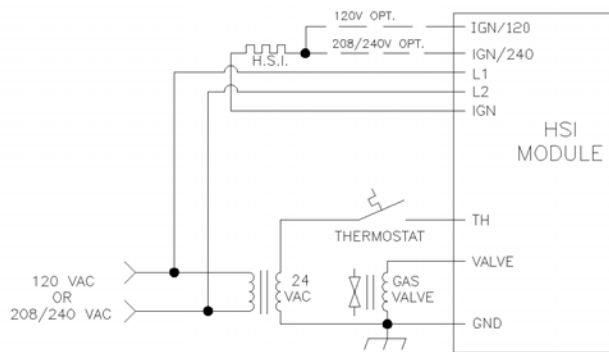

Figure 1a: 05-33 without Inducer wiring diagram

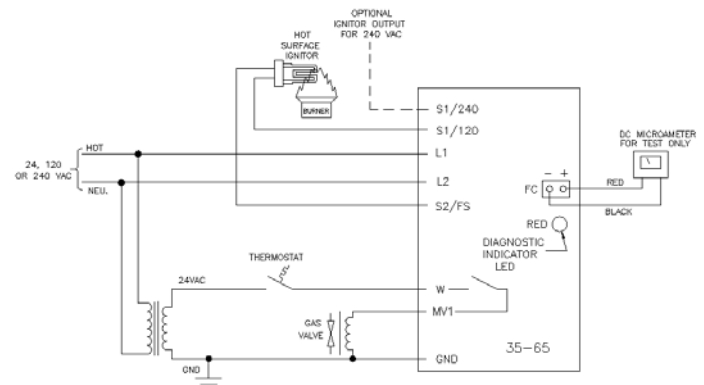

Figure 1b: 35-65 wiring diagram

Remote Sense

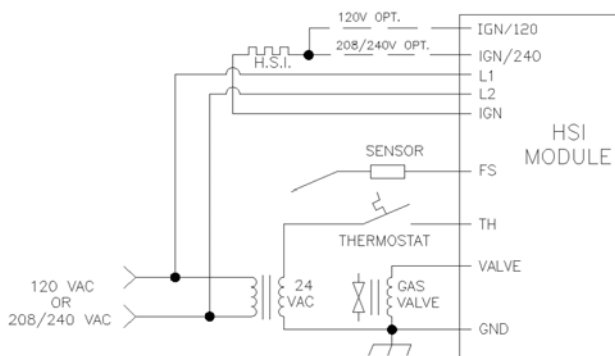

Figure 2a: 05-33 without Inducer wiring diagram

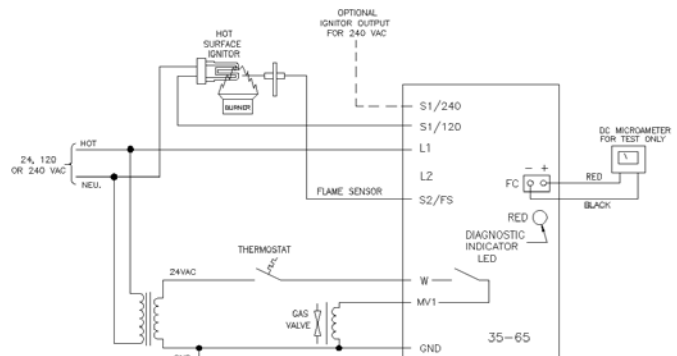

Figure 2b: 35-65 wiring diagram

05-33 to 35-66 Wiring Comparison

Local Sense

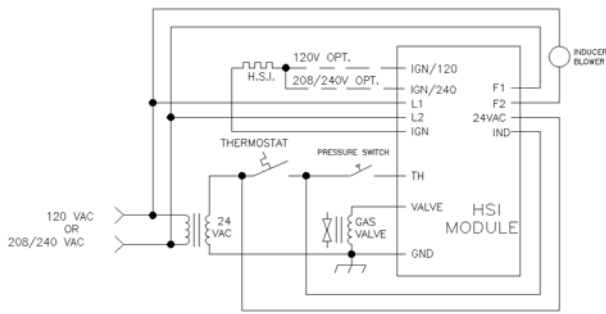

Figure 3a: 05-33 with Inducer wiring diagram

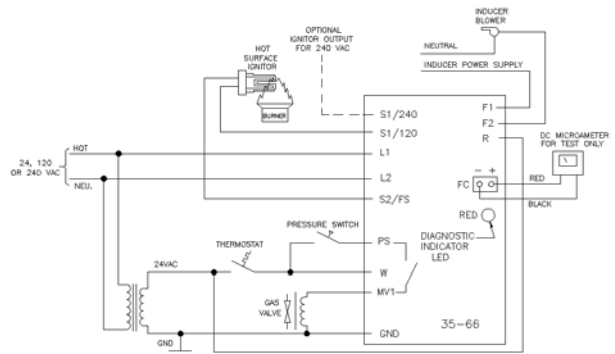

Figure 3b: 35-66 wiring diagram

Remote Sense

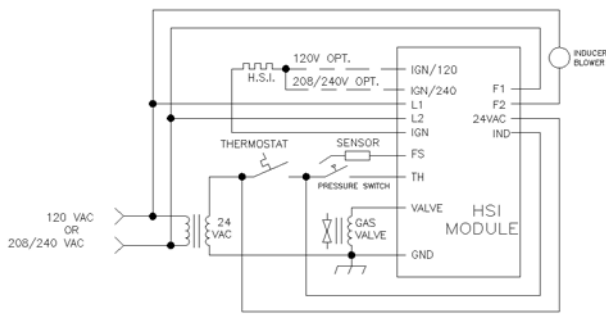

Figure 4a: 05-33 with Inducer wiring diagram

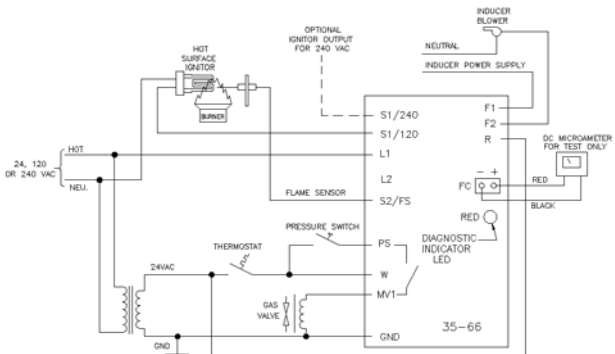

Figure 4b: 35-66 wiring diagram

05-33 to 35-65 / 35-66 Dimension Comparison

05-33

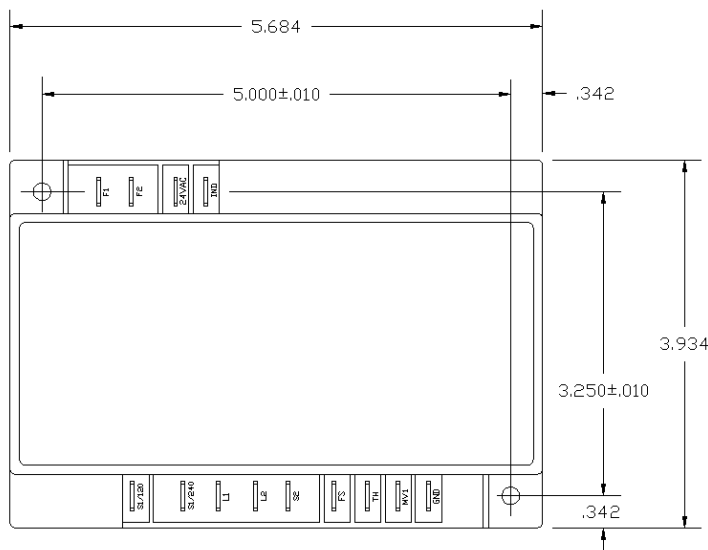

Figure 5a: 05-33 dimensions (front)

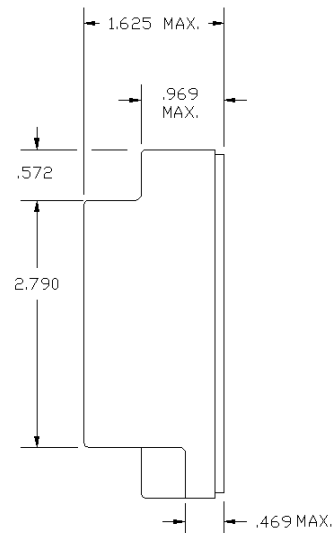

Figure 5b: 05-33 dimensions (side)

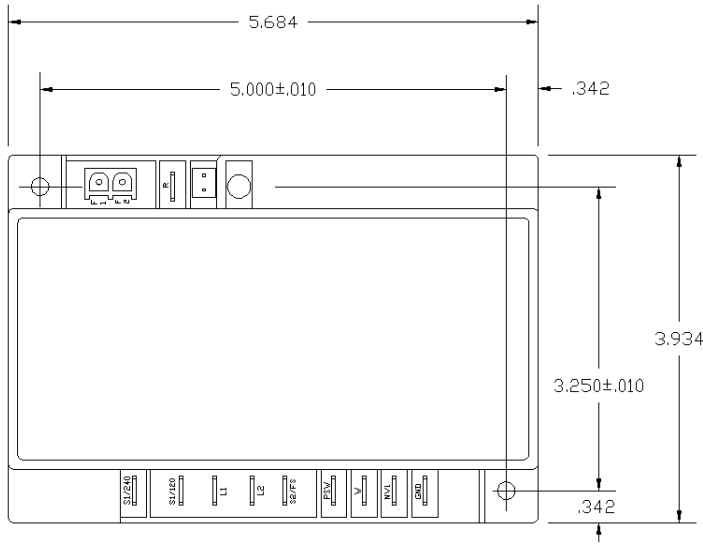

Figure 6a: 35-65 / 35-66 dimensions (front)

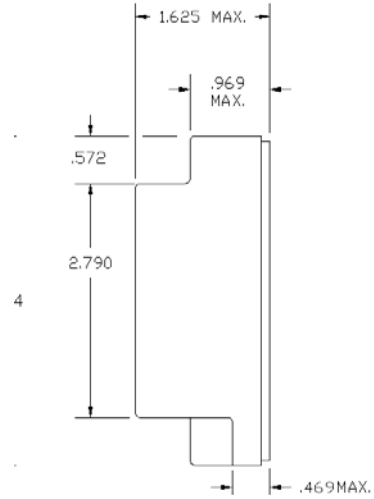

Figure 6b: 35-65 / 35-66 dimensions (side)

05-33 to 35-65 / 35-66 Conversion Chart

Part Number	Replacement	Notes
05-331361-012	35-662615-001	
05-332161-103	35-662535-113	60 Second Post Purge
05-332461-103	35-665535-113	60 Second Post Purge
05-339001-002	35-665535-011	
05-339003-103	TO BE ASSIGNED	
05-339007-103	TO BE ASSIGNED	
05-339013-003	TO BE ASSIGNED	
05-339014-103	TO BE ASSIGNED	
05-339015-103	TO BE ASSIGNED	
05-339016-003	TO BE ASSIGNED	
05-339018-103	TO BE ASSIGNED	



KIDDE-FENWAL, INC.
 400 MAIN STREET, ASHLAND, MA 01721
 TEL: (508) 881-2000 FAX: (508) 881-6729
www.fenwalcontrols.com

These instructions do not purport to cover all the details or variations in the equipment described, nor do they provide for every possible contingency to be met in connection with installation, operation and maintenance. All specifications subject to change without notice. Should further information be desired or should particular problems arise which are not covered sufficiently for the purchaser's purposes, the matter should be referred to KIDDE-FENWAL, Inc., Ashland, MA.