

Conversion Guide



05-38 to 35-70 Series 120 VAC Direct Spark Ignition Control

CG 05.38 to 35.70

Fenwal continues advancing direct spark gas ignition technology by employing its legendary design experience to develop a new line of microprocessor based ignition controls for the 120 VAC marketplace. The 35-70, 120 VAC DSI is the most recent advance in Fenwal's broad product mix to serve this market. Providing safe gas ignition control and flame monitoring for 120 VAC gas burner systems, the 35-70's microprocessor based design offers a wide range of configurations in a cost effective package.

The 35-70 is the latest in a long line of 120 VAC controls and replaces the following Fenwal analog controls: the 05-13 (circa 1960), 05-14 (circa 1970) and 05-38 (circa 1985). This conversion guide provides information to quickly and safely convert an application from the 05-38 to the 35-70.

The 35-70's microprocessor design offers significant advantages over its analog predecessors by providing:

- Extremely precise ignition and purge timings
+/- 5% accuracy versus +/- 20% for the previous controls
- LED diagnostics for accurate and fast troubleshooting
- Improved flame sensitivity for difficult applications and prevention of nuisance lockouts
- Polarity insensitive wiring
- Reduced footprint for space limited applications
- Multiple methods for lockout recovery
- Software based customization for ignition and purge timings

This guide includes:

- Agency approval comparisons
- Terminal designation and size comparison
- Single Spark and Sense vs. Local Sense electrode wiring
- Control wiring comparison
- Footprint comparisons
- Conversion list for most popular controls

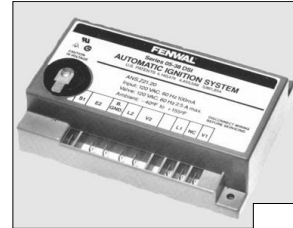

05-38

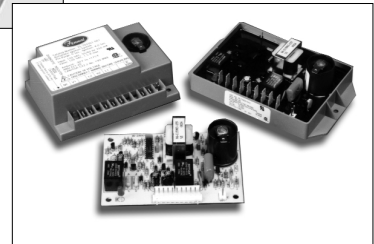

35-70

Along with the 35-70, Fenwal is proud to offer two additional controls (35-71, 35-72) as part of the 35-7X family of 120 VAC Direct Spark Ignition Controls. These products are designed to match the features and price needs of a wide variety of applications.



- **35-72 DSI Control** - The "Base Model" is ideal for commodity products where simple ignition control is required and price is a major determining factor.



- **35-71 DSI Control** - Provides combustion blower relay control and monitors the pressure switch with LED diagnostics and flame sense test pins, ideal for those customers who prefer more integration to reduce component count and system wiring.

Agency Comparison

AGENCY APPROVAL	35-70	05-38
UL 372, UL 1998 Software	Approved	Approved
CSA: ANSI Z21.20, CAN/CSA-C22.2 No. 199-M89	Approved	Approved
FM: Ignition Device and Flame Safeguard	*Approved	* *Certain Models

* The 35-70 Series has been FM approved by Factory Mutual as both an ignition device and flame safeguard. FM certification allows only single trial for ignition models with up to 15 second Trial for Ignition time.

* * The 05-38 models that are FM approved have a single try for ignition with a minimum of 5 seconds for pre-purge to prove that no flame is present. The TFI time must be less than 10 seconds.

Terminal Designation and Size Comparison

Description	TERMINAL DESIGNATION		QUICK CONNECT TERMINAL		MULTIPIN CONNECTOR	
	35-70	05-38	35-70	05-38	35-70 ONLY	
					PIN LOCATION	WIRE COLOR
Alarm	NC	NC	1/4"	1/4"	11	Lt. Blue
Valve Power	V1	V1	3/16"	1/4"	10	Brown
120 VAC (Neutral)	L2	L2	3/16"	1/4"	8	White
Valve Neutral	V2	V2	3/16"	1/4"	7	Yellow
120 VAC Input (Hot)	L1	L1	1/4"	1/4"	6	Black
Burner Ground	B.GND	B. GND	3/16"	1/4"	2	Purple
Remote Flame Sensor	S1	S1	1/4"	1/4"	1	Gray
Local Sense	N/A	E2	N/A	1/4"	N/A	N/A
Flame Sense Test Pins	FC+,FC-	N/A	.045" SQ	N/A		2 Pin Header

Terminology - Single Spark and Sense vs. Local Sense

One important note on wiring the 35-70 has to do with terminology and wiring for flame sense. In all of the new 120 VAC control literature, especially that for the 35-70, we have made a point to use the term "Single Spark and Sense" rather than the more colloquial "Local Sense" when referring to sensing flame on the spark electrode. Local Sense versions of the 05-38s have the flame sense signal travel to the board along a separate wire (not the H.V. wire) to a terminal on the control typically identified as E2. This is a very important distinction. Single Spark and Sense is easier to wire as it eliminates the need for an additional sense wire, because the high voltage wire serves the dual role of supplying spark energy to the electrode and passing the flame sense current to the control.

New Grounding Scheme

For all models of the 35-70, the B.GND terminal is used to ground the burner and to complete the flame current signal circuit. This terminal must be connected to the burner (chassis) ground not only to ensure the best, long term, stable flame signal, but also to ground the burner for proper sparking, especially in the case of single spark and sense. See wiring diagrams for conversion of 05-38 to 35-70 wiring.

The use of a burner ground terminal eliminates the problem of loss of flame sense signal due to a missing or loose neutral or ground (green) wire at the 120 VAC power source. The 35-70 has been designed such that reversing the polarity of the 120 VAC line does not cause a loss of flame signal. Thus, the 35-70 provides a more reliable flame signal along with a reduction of nuisance lockouts, due to its design and the use of the B.GND terminal.

Electrode requirements for Single Spark and Sense vs. Local Sense Applications

Since 05-38s with Local Sense are replaced by 35-70s with Single Spark and Sense, the electrode must be re-wired or replaced with a simpler electrode configuration. Typically, a local sense electrode, see figure below, has two electrodes on the same bracket. This type of electrode assembly requires that a high voltage wire and flame sense wire be attached to each electrode and wired back to the control. A single spark and sense electrode has only one electrode on the bracket and requires just the high voltage wire and a grounded burner. See Figure 1 below.

Figure 1:

SINGLE SPARK AND SENSE VS. LOCAL SENSE WIRING

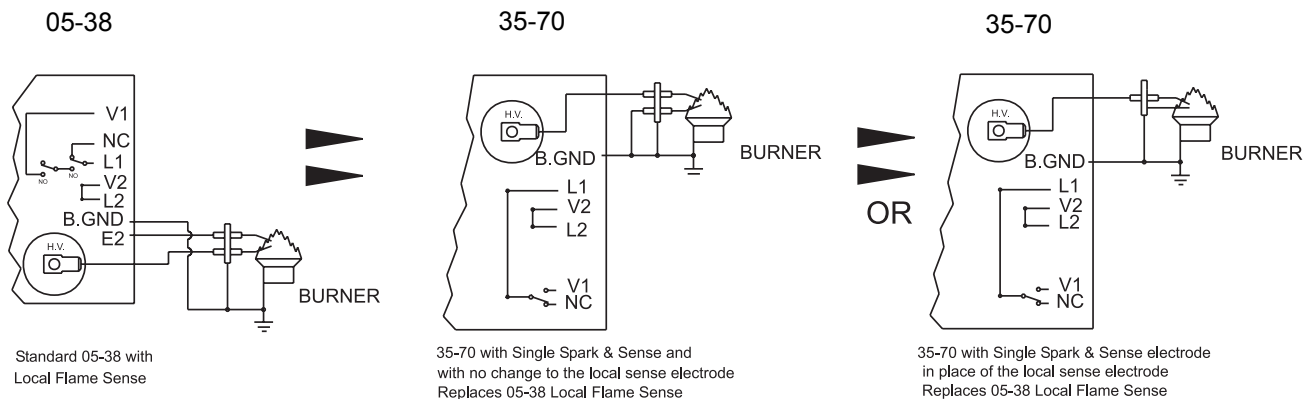

05-38 to 35-70 Wiring Comparison

SINGLE SPARK AND SENSE

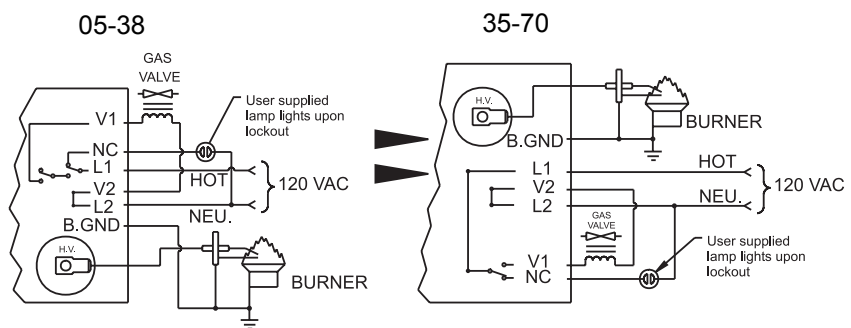

Figure 1:a 05-38 with Single Spark & Sense

Figure 1:b 35-70 with Single Spark & Sense
Replaces 05-38 with Single Spark & Sense

LOCAL SENSE

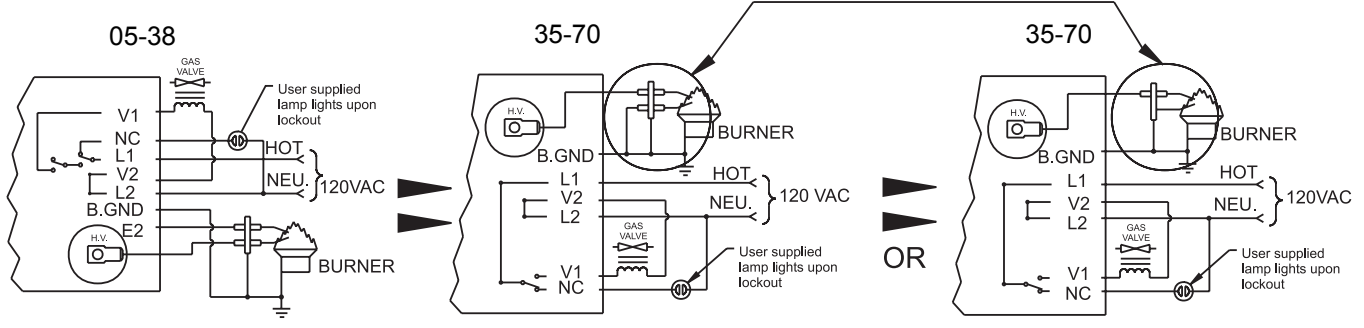

Figure 2:a 05-38 with Local Flame Sense

Figure 2:b 35-70 with Single Spark & Sense.
with no change to the local sense electrode
Replaces 05-38 Local Flame Sense

Figure 2:c 35-70 with Single Spark & Sense electrode
in place of the local sense electrode
Replaces 05-38 Local Flame Sense

REMOTE SENSE

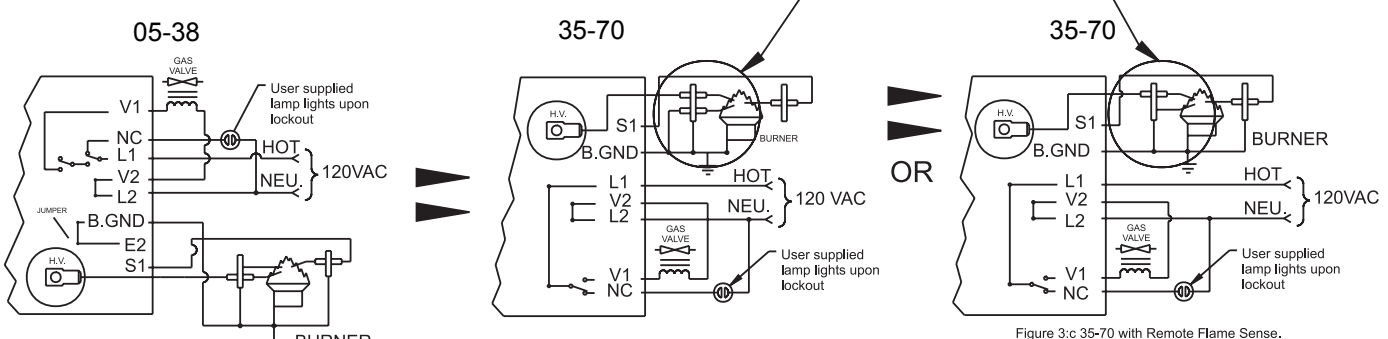

Figure 3:a 05-38 with Remote Flame Sense

Figure 3:b 35-70 with Remote Sense
using existing spark and remote sense electrodes
Replaces 05-38 with Remote Flame Sense

Figure 3:c 35-70 with Remote Flame Sense.
Using Single Spark and Sense Electrode in
place of Local Sense Electrode
Replaces 05-38 Remote Sense.

05-38 to 35-70 Footprint Comparison

05-38 POTTED

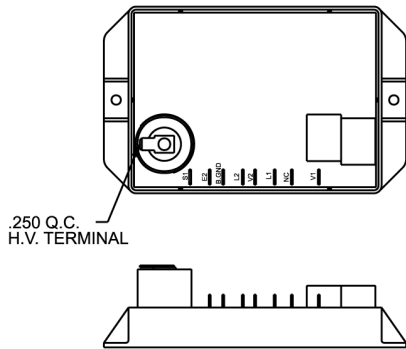

35-70 POTTED

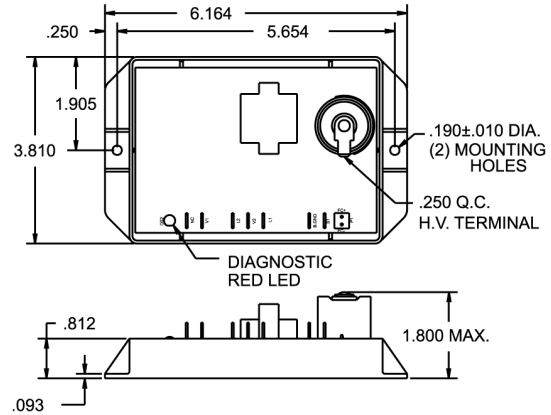

THE 05-38 AND 35-70 POTTED CONTROLS HAVE THE SAME FOOTPRINT.
PLEASE NOTE THE LOCATION OF THE H.V. TERMINAL WHEN CONSIDERING WIRING.

05-38 CASE AND COVER

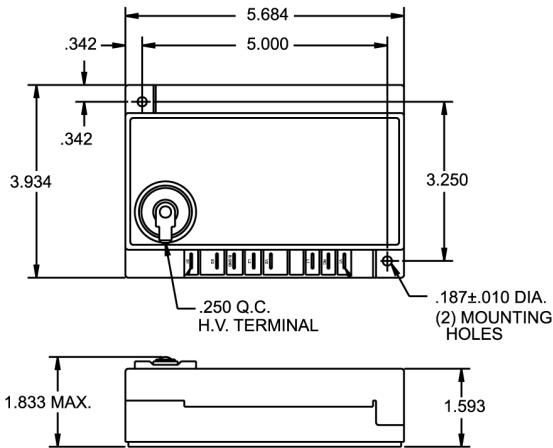

35-70 CASE AND COVER

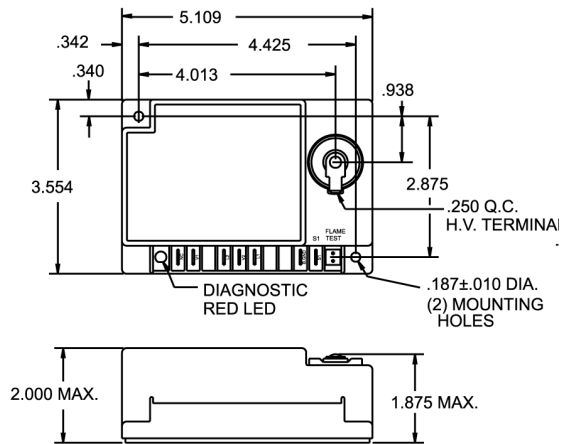

PLEASE NOTE THE LOCATION OF THE H.V. TERMINAL WHEN CONSIDERING WIRING.

05-38 STAND-OFF

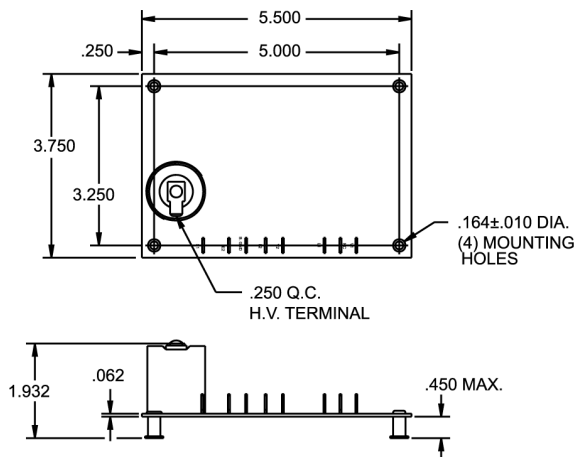

35-70 STAND-OFF

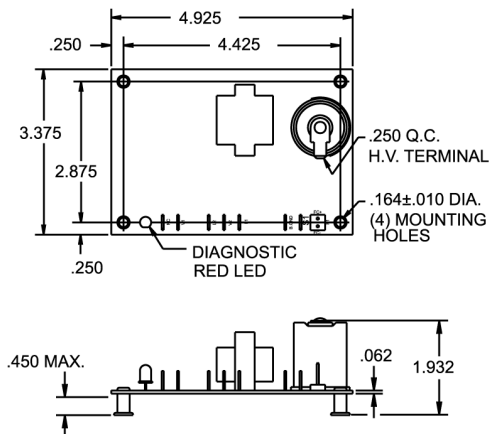

PLEASE NOTE THE LOCATION OF THE H.V. TERMINAL WHEN CONSIDERING WIRING.

05-38 to 35-70 Conversion Chart (continued)

EXISTING PART NUMBER	35-70 CROSS REFERENCE	NOTES
05-384641-253	35-705505-223	Electrically interchangeable though some terminal sizes on the 35-70 are smaller, see chart on top of page 2
05-384641-256	35-705505-225	Electrically interchangeable though some terminal sizes on the 35-70 are smaller, see chart on top of page 2
05-384641-550	35-705505-511	Electrically interchangeable though some terminal sizes on the 35-70 are smaller, see chart on top of page 2
05-384642-156	35-705705-115	Electrically interchangeable though some terminal sizes on the 35-70 are smaller, see chart on top of page 2; potted, see note 1 below
05-389000-551	35-705600-501	Electrically interchangeable though some terminal sizes on the 35-70 are smaller, see chart on top of page 2
05-389002-755	35-705500-005	Electrically interchangeable though some terminal sizes on the 35-70 are smaller, see chart on top of page 2
05-389003-751	35-705601-001	Electrically interchangeable though some terminal sizes on the 35-70 are smaller, see chart on top of page 2
05-389004-555	35-705500-505	Same as 05-384601-555, components added to control to improve flame sense
05-389006-750	35-705500-001	Electrically interchangeable though some terminal sizes on the 35-70 are smaller, see chart on top of page 2
05-389008-151	35-705701-101	Same as 05-384402-151 with NC and E2 terminals removed, 6" lead wire with 1/4" insulated Q.C. for S1
05-389010-555	35-705505-515	A special feature part number has been assigned to the 05-38 because it has a vertical 1/4" Q.C. terminal on the high voltage transformer rather than the standard horizontal 1/4" Q.C. terminal; 3 tries for ignition, see note 2 below
05-389011-753	35-715901-115	Electrically interchangeable though some terminal sizes on the 35-70 are smaller, see chart on top of page 2
05-389018-555	35-705500-505	Electrically interchangeable though some terminal sizes on the 35-70 are smaller, see chart on top of page 2

NOTE 1: 05-38 controls with part numbers having a 2 in the following location, 05-38XXX2-XXX are not identified in the 05-38 part numbering scheme in the 05-38 data sheet. The 2 indicates that the control is enclosed in an open top potting shell and encased in dielectric potting material for protection against washdown and extreme vibration.

NOTE 2: 05-38 controls with part numbers having a 5 in the following location, 05-38XXX-5XX are not identified in the 05-38 part numbering scheme in the 05-38 data sheet. The 5 indicates that the control has a 5 second prepurge. On 05-38s with three trials for ignition the default interpurge time is 5 seconds. The corresponding 35-70 that has a 5 second pre purge and three trials for ignition will have a 15 second interpurge.



400 MAIN STREET, ASHLAND, MA 01721
 TEL: (508) 881-2000
 FAX: (508) 881-6729
 www.fenwalcontrols.com

These instructions do not purport to cover all the details or variations in the equipment described, nor do they provide for every possible contingency to be met in connection with installation, operation and maintenance. All specifications subject to change without notice. Should further information be desired or should particular problems arise which are not covered sufficiently for the purchaser's purposes, the matter should be referred to KIDDE-FENWAL, Inc., Ashland, Massachusetts.



© 2001 Kidde-Fenwal, Inc, Printed in U.S.A. CP 06-236176-002 REV AA