

SERIES 35-60

24 VAC Microprocessor-Based Direct Spark Ignition Control

parts4heating
800-536-1582 Fax: 866-448-9304
info@parts4heating.com



35.60.03

FEATURES

- 24 VAC microprocessor based DSI control
- System diagnostic LED
- Automatic reset 1 hour after lockout*
- Multiple tries for ignition
- Custom prepurge and interpurge timings**
- Remote or local flame sensing
- Flame sense test pins

APPLICATIONS

- Gas Furnaces
- Boilers
- Water Heaters
- Commercial Cooking and other Similar Appliances

DESCRIPTION

The Series 35-60 is a 24 VAC Microprocessor Based Direct Spark Ignition Control designed for use in all types of heating applications. The control utilizes a microprocessor to continually and safely, analyze and control the proper operation of the gas burner. Value added features such as LED diagnostics, automatic one hour reset, and flame current test pins highlight the controls benefits.

Agency Certifications



UL Component Recognized System.
Design certified to UL 372, file MH8817.
Software conforms to UL 1998 requirements.



Design certified to ANSI Z21.20, and EN 298
CAN/ CSA C22.2 No. 199-M89



CE Approved to EN 298:2003

* **US Versions Only**

** **Prepurge Time Cannot Exceed Interpurge
Time on European Models**



SPECIFICATIONS

Input Power	Control: 18-30 VAC 50/60 Hz (Class 2 Transformer)
Input Current Drain	300 mA @ 24 VAC and gas valve relay energized (control only)
Gas Valve Rating	2.0A @ 24 VAC
Operating Temperature	-40°F to +160°F -40°C to +71°C
Flame Sensitivity	.7µA minimum
Flame Failure Response Time	0.8 seconds maximum
Types of Gases	Natural, LP, or manufactured
Spark Rate	Line frequency (50/60 sparks/ sec.)
Size (LxWxH)	5.69 x 3.94 x 1.87 inches (with cover) 14.45 x 10.0 x 4.75 cm (with cover)
Weight	8 ounces (nominal) 224 grams (nominal)
Enclosure	Gray (Noryl N-190) fire retardant plastic Integral standoffs optional
Moisture Resistance	Conformal coated to operate to 95% R.H. Care must be taken to protect module from direct exposure to water
Tries for ignition	One or three try versions available
Trial for ignition Periods	4.0, 7.0, 10.0, or 15.0 seconds standard Contact factory for other settings
Prepurge & Interpurge	None, 15, or 30 seconds depending on model. Without prepurge there is a one second delay before the first try for ignition
Edge Connect Version	Optional Edge connect model for replacement product

SEQUENCE OF OPERATION / FLAME RECOVERY/ SAFETY LOCKOUT

Start up - Heat Mode

When a call for heat is received from the thermostat supplying 24 volts to TH, the control will reset, perform a self check routine, flash the diagnostic LED, and a pre-purge delay begins. Following the pre-purge period the gas valve is energized and sparks commence for the trial for ignition period.

When flame is detected during the trial for ignition, sparks are shutoff immediately and the gas valve remains energized. The thermostat and main burner flame are constantly monitored to assure the system continues to operate properly. When the thermostat is satisfied and the demand for heat ends, the main valve is de-energized immediately.

Failure to Light - Lockout

SINGLE TRIAL MODEL

Should the main burner fail to light, or flame is not detected during the trial for ignition period, the control will go into lockout and the valve will be turned off immediately.

MULTI TRIAL MODEL

Should the main burner fail to light, or flame is not detected during the first trial for ignition period, the gas valve is de-energized and the control goes through an interpurge delay before another ignition attempt. The control will attempt two additional ignition trials before going into lockout and the valve relay will be de-energized immediately.

Recovery from lockout requires a manual reset by either resetting the thermostat for a period of 5 seconds.

If the thermostat is still calling for heat after one hour the control will automatically reset and attempt to ignite the burner again.

Flame Failure - Re-Ignition

If the established flame signal is lost while the burner is the control will respond within 0.8 seconds. The HV spark will be energized for a trial ignition period in an attempt to relight the burner. If the burner does not light the control will de-energize the gas valve. Multi-try models will make two more attempts to relight the burner. If the burner does not relight the control will go into lockout as noted above in "Failure to light". If flame is re-established, normal operation resumes.

Recycle After Loss Of Flame

The option "recycle after loss of flame" may be selected as a special feature. With this option, upon loss of flame, the gas valve is de-energized and the control recycles its sequence of operation. Controls with no prepurge will begin with the first trial for ignition period. Multi-try models will allow three tries for ignition including interpurges. Controls with pre-purge delay will

begin with pre-purge, allowing single or multiple trials for ignition depending on model. If burner relights, normal operation resumes, if burner does not relight, control will go into lockout as described in "failure to light".

Fault Conditions

Error Mode	LED Indication
Internal Control Failure	Steady on
Flame with No Call for heat	2 flashes
Ignition Lockout	3 flashes

The LED will flash on for 1/4 second, then off for 1/4 second during a fault condition. The pause between fault codes is 3 seconds.

MOUNTING AND WIRING

The Series 35-60 is not position sensitive and can be mounted vertically or horizontally. The case may be mounted on any surface with #6 sheet metal screws.



WARNING: All wiring must be done in accordance with both local and national electrical code.

WARNING: The Series 35-60 uses voltages of shock hazard potential. Wiring and initial operation must be done by a qualified service technician.

The control must be secured in an area that will experience minimum vibration and remain below the maximum operating temperature of 160°F.

All connections should be made with UL approved 105°C rated 18 gauge, stranded, .054 thick insulated wire. Refer to wiring diagram when connecting the Series 35-60 to other components in the system.

TERMINAL DESIGNATIONS	
TH	Thermostat Input
GND	System Ground
V1	Valve Power
V2	Valve Ground
NC	Alarm (normally closed contact)
S1	Remote Flame Sensor
FC+, FC-	Flame Current Test Pins



CAUTION: Label all wires prior to disconnection when servicing controls. Wiring errors can cause improper and dangerous operation. A functional checkout of a replacement control is recommended.

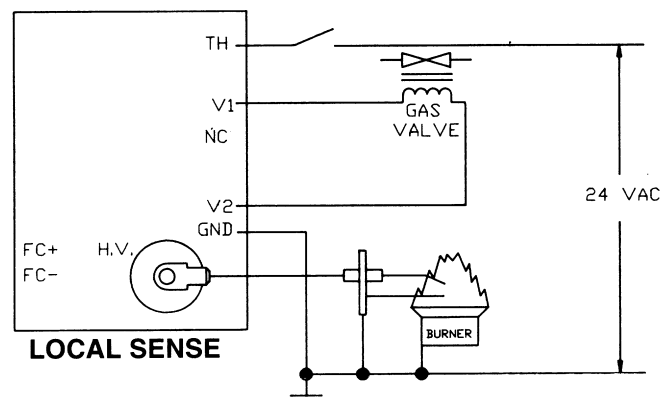

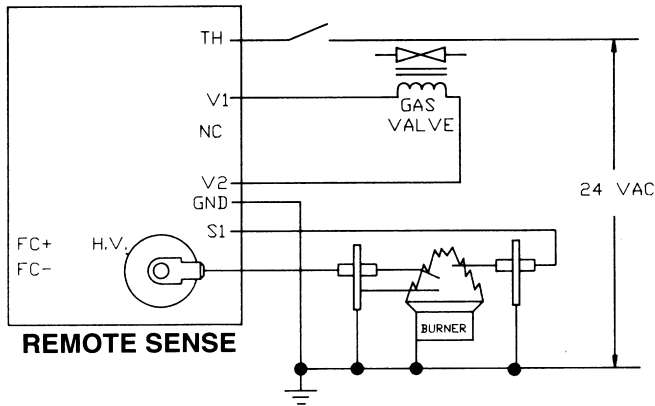

PROPER ELECTRODE LOCATION

Proper location of the electrode assembly is important for optimum system performance. It is recommended that electrode assembly be mounted temporarily using clamps or other suitable means so that the system can be checked before permanently mounting the assembly. The electrode assembly should be located so that the tips are inside the flame envelope and about 1/2 inch (1 cm) above the base of the flame. See Figure 3.



CAUTIONS:

1. Ceramic insulators should not be in or close to the flame.
2. Electrode assemblies should not be adjusted or disassembled. Electrodes should have a gap spacing of 0.125 ± 0.031 in (3.12 ± 0.81 mm). If this spacing is not correct, the assembly must be replaced. Electrodes are NOT field adjustable.
3. Exceeding the temperature limits can cause nuisance lockouts and premature electrode failure.
4. Electrodes must be placed where they could not be exposed to the appliance user in normal operation.

Ignitor Location

Figure 3

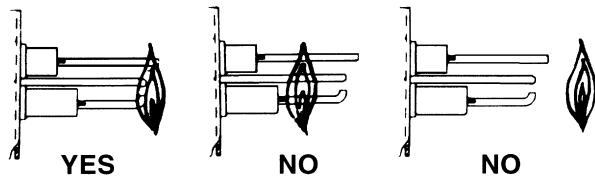

WARNING:

Operation outside specifications could result in failure of the Fenwal product and other equipment with injury to people and property.

High Voltage Cable

Fenwal Part Number 05-129608-624 Suppression Cable (or equivalent) must be used for proper operation of control.

TROUBLESHOOTING GUIDE

SYMPTOM	RECOMMENDED ACTIONS
1. Dead	A. Miswired B. Transformer bad C. Fuse/Circuit breaker bad D. Bad control (check LED for steady on)
2. Thermostat on- no spark	A. Miswired B. Bad thermostat C. No voltage at terminal TH
3. Valve on, no spark	A. Shorted electrode B. Open HV cable C. Miswired D. Bad control
4. Spark on, no valve	A. Valve coil open B. Open valve wire C. Bad control (check voltage between V1 & V2)
5. Flame OK during TFI, no flame sense after TFI	A. Bad electrode B. Bad S1 or HV wire C. Poor ground at burner D. Poor flame (check flame current)

FLAME SENSOR CURRENT CHECK

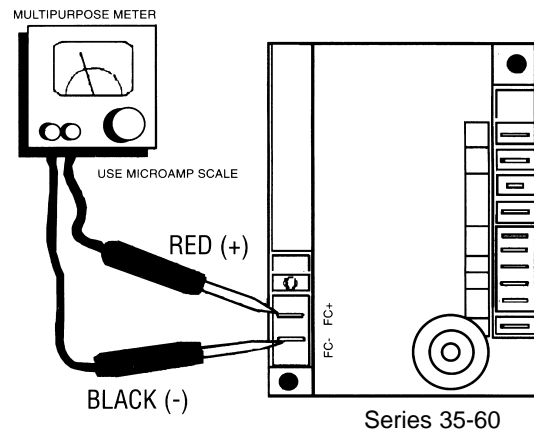

SERVICE CHECKS

Flame current is the current which passes through the flame from the sensor to ground. The minimum flame current necessary to keep the system from lockout is .7 microamps. To measure flame current, connect an analog DC microammeter to the FC-FC+ terminals per figure. Meter should read .7 uA or higher. If the meter reads below "0" on scale, meter leads are reversed. Disconnect power and reconnect meter leads for proper polarity.

SERIES 35-605 X X X -X X X

Special Options

- No Cover
- No Diagnostics
- Recycle after Loss of Flame
- No Automatic Reset

*European Versions
 Diagnostics and test pins are not available on European version.

**Non-Standard Configurations

9 = Non Standard Configuration

A 9 in this location of the part number (i.e. 35-60 5 **901** -113) identifies this configuration as a non-standard design. The part number does not follow the part numbering system. The 9XX is a sequential part number assigned by Fenwal. Consult factory for operating characteristics of this control.

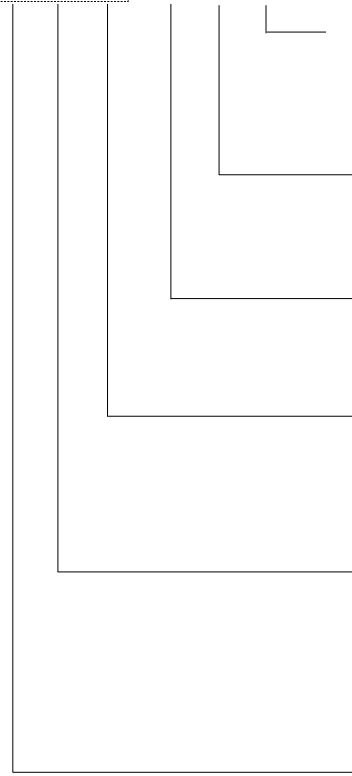

Trial for Ignition

- 1= 4 Seconds
- 3= 7 Seconds
- 5= 10 Seconds
- 7= 15 Seconds

Inter-Purge

- 0= None (Single Try Only)
- 1= 15 Seconds
- 2= 30 Seconds

Pre-Purge

- 0= None
- 1= 15 Seconds
- 2= 30 Seconds

Tries for Ignition and Methods for Flame Sense

- 0= Single Try - Local Sense
- 1= Single Try - Remote Sense
- 5= Three Tries - Local Sense
- 6= Three Tries - Remote Sense

Enclosure

- 0= Noryl Gray Enclosure
- 1= Integral Standoffs
- 2= HHVT w/Enclosure (Edge Connect Version Only)
- 3= HHVT No Enclosure (Edge Connect Version Only)
- 5= Mate-N-Lock W/Enclosure
- 6= Mate-N-Lock W/Standoffs

Product Designation

- 2= Standard European Version*
- 3= Special European Version*
- 5= Standard
- 6= Edge Connector
- 8= Aftermarket Kit
- 9= Non-Standard**

DIMENSIONS

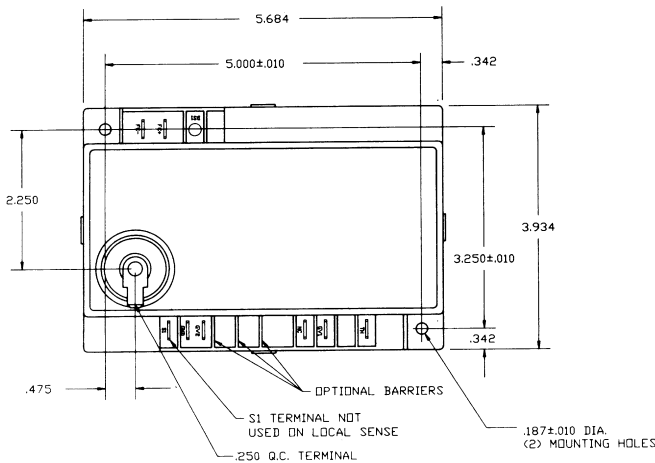

Model with Enclosure

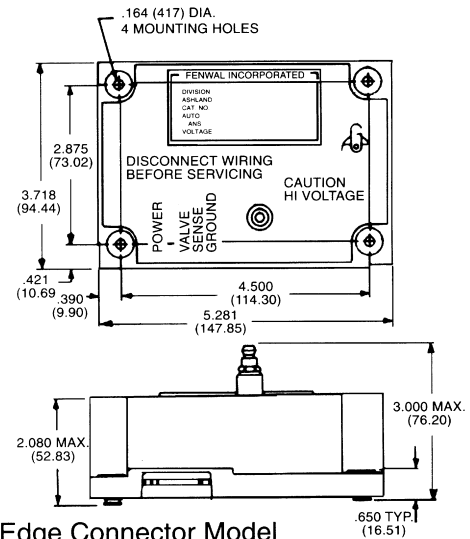

Edge Connector Model
 (NOT AVAILABLE ON EUROPEAN MODELS)



FENWAL
 400 MAIN STREET, ASHLAND, MA 01721
 TEL: (508) 881-2000 FAX: (508) 881-6729
 www.fenwalcontrols.com

These instructions do not purport to cover all the details or variations in the equipment described, nor do they provide for every possible contingency to be met in connection with installation, operation and maintenance. All specifications subject to change without notice. Should further information be desired or should particular problems arise which are not covered sufficiently for the purchaser's purposes, the matter should be referred to KIDDE-FENWAL, Inc., Ashland, Massachusetts.