

SERIES 35-63J



24 VAC Microprocessor Based Intermittent Pilot Ignition Control Johnson Controls G77x Series Replacement

35-63J

FEATURES

- Drop-in replacement for JCI G77x series
- Safe Start and full-time flame sensing
- Custom prepurge and interpurge timings
- Multiple trials for ignition
- Diagnostic LED using Fenwal fault codes
- Three ground terminals for ease of wiring
- Remote or local flame sense options
- Automatic 5 min or 1 hour reset after lockout options

APPLICATIONS

Directly replaces Johnson Controls G77x in:

- Commercial cooking equipment
- Commercial gas furnaces
- Unit heaters
- Water heaters

Consider the Fenwal 35-63J for IP ignition applications where a smaller footprint is desirable

DESCRIPTION

The Fenwal 35-63 "J" Series provides all the features, performance and reliability of our 35-63 Series 24 VAC intermittent pilot (spark-to-pilot) ignition control in a Johnson Controls format.

Designed to directly replace the Johnson G77x Series, the Fenwal 35-63J matches the footprint, mounting hole pattern, and wiring connections of the discontinued Johnson series.

ADVANTAGES

- **Microprocessor control** for precise, repeatable timings and operating sequences
- **Fenwal Platform Design** for easy customization of ignition cycle and timings to appliance requirements
- **High Spark Energy** for fast, dependable burner ignition
- **Superior 120V Flame Sense Signal** provides safe, reliable burner operation (vs. 24V design)
- **On-board diagnostics** with LED display for efficient operation and easy troubleshooting

Agency Certifications



Design certified to ANSI Z21.20,
CAN/CSA C22.2 No. 199-M99.

NOTE:

For the Direct Spark Ignition version comparable to the Johnson G76X Series, see Fenwal 35-60J

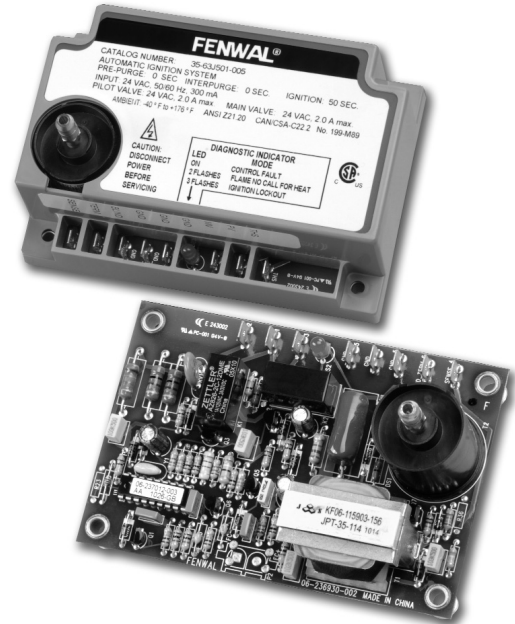

SPECIFICATIONS

Input Power	Control: 18-30 VAC 50/60 Hz (Class 2 Transformer)
Input Current Drain	300 mA @24 VAC with gas and pilot relays energized (Control only)
Main Gas Valve	2.0A max (continuous)
Pilot Gas Valve	2.0A max (continuous)
Operating Temperature	-40°F to +176°F (-40°C to +80°C)
Storage Temperature	-40°F to +185°F (-40°C to +85°C)
Flame Sensitivity	0.3 µA minimum
Flame Failure Response or Re-ignition Time	0.8 seconds maximum
Flame Detector Self-check Rate	Once per second minimum
Types of Gas	Natural, LP, or manufactured
Spark Rate	Remote sense (50/60 Hz) Local sense (25/30 Hz)
Size (LxWXH)	4.92 x 3.32 x 2.71 inches (with cover) 12.50 x 8.43 x 6.88 cm (with cover)
Weight	8 ounces (nominal) 224 grams (nominal)
Moisture Resistance	Conformal coated to operate to 95% R.H. (non-condensing)
Tries for Ignition	One or three try versions available
Trial for Ignition Periods	8, 25, 50, 85, 120 seconds available
Prepurge Timings	None, 4, 15, or 30 seconds available
Interpurge Timings	None, 15, 30, or 45 seconds available

SEQUENCE OF OPERATION / FLAME RECOVERY / SAFETY LOCKOUT

Start Up - Heat Mode

When a call for heat is received from the thermostat supplying 24 volts to THS, the control will reset, perform a self check routine, flash the diagnostic LED once in the first two seconds, and a pre-purge delay begins. Following the pre-purge period, the pilot gas valve is energized and sparks commence for the trial for ignition period. The main gas valve remains de-energized until the pilot flame is detected.

When the pilot flame is detected during the trial for ignition, the sparking process is terminated and the main gas valve is energized. The thermostat signal and pilot burner flame are constantly monitored to assure the system continues to operate properly. When the thermostat is satisfied and the demand for heat ends, the pilot and main valves are de-energized immediately.

Failure to Light - Lockout

SINGLE TRIAL MODEL

Should the pilot burner fail to light, or if the pilot flame is not detected during the trial for ignition period, the control will go into lockout. The valves are de-energized immediately. The LED will indicate the code for ignition lockout.

MULTI TRIAL MODEL

Should the pilot burner fail to light, or if the pilot flame is not detected during the first trial for ignition period, the pilot and main gas valves are de-energized. The control then goes through an interpurge delay before another ignition attempt. The control will attempt two additional ignition trials before going into lockout and the valve relays will be de-energized immediately.

Recovery from lockout requires a manual reset by either resetting the thermostat or removing 24 volts for a period of 5 seconds. On models with automatic reset, if the thermostat is still calling for heat after 5 minutes the control will automatically reset and attempt to ignite the burner.

Flame Failure - Recycle Mode (standard)

With "recycle after loss of flame", upon loss of pilot flame, both the pilot and main gas valves are de-energized and the control proceeds to interpurge before attempting to relight the pilot flame. Multi-try models will allow three tries for ignition including interpurges. If the pilot burner relights, normal operation resumes. If the pilot burner does not relight, the control will go into lockout as described in "Failure to Light".

Flame Failure - Re-ignition Mode (optional)

If the established pilot flame signal is lost while the burner is operating, the control will respond within 0.8 seconds by de-energizing the main gas valve and energizing the HV spark in an attempt to relight the pilot burner for the programmed TFI period. If the pilot burner does not light within the TFI, the pilot gas valve is de-energized immediately and on multi-try

models a new TFI sequence begins. If the pilot burner does not relight, the control will lockout as previously described in the "Failure to Light" section. Multi-try models will make two more attempts to light the burner. If pilot flame is re-established, normal operation resumes.

TABLE 1 - FAULT CONDITIONS

LED INDICATION	FAULT MODE
2 Flashes	Pilot Flame without call for heat
3 Flashes	Ignition Lockout
Steady On	Internal Control Failure

The LED will flash on for 1/4 second, then off for 1/4 second during a fault condition. The pause between fault codes is 3 seconds.

Internal Control Failure:

If the control detects an error in its software or hardware, all outputs are turned off and the LED displays a steady ON condition.

MOUNTING AND WIRING

The Series 35-63J is not position sensitive and can be mounted vertically or horizontally. The case may be mounted on any surface with #6 sheet metal screws.



CAUTION:

Label all wires prior to disconnection when servicing controls. Wiring errors can cause improper and dangerous operation. There are no field replaceable components inside the control. It must be replaced in whole.

TABLE 2 - WIRING TERMINALS

TERMINAL	DESCRIPTION	QUICK CONNECT
THS	Thermostat Input	1/4 inch
PV	Pilot Valve Power	1/4 inch
MV	Main Valve Power	1/4 inch
_GND	Valve Ground	1/4 inch
GND_	Valve Ground	1/4 inch
GND	System Ground	1/4 inch
BLIND	No Connection	1/4 inch
SENSE	Remote Flame Sensor	1/4 inch
HV	High Voltage Output	Rajah



WARNING:

The control must be located and mounted in a manner that protects components from exposure to water (dripping, condensate, spraying, rain). Any control that has been exposed to water must be replaced.



WARNING:

All wiring must be done in accordance with both local and national electrical code. Wiring must be at least #18 AWG rated for 105°C or higher.



WARNING:

The Series 35-63J uses voltages of shock hazard potential. Wiring and initial operation must be done by a qualified service technician.



WARNING:

Operation outside specifications could result in failure of the Fenwal product and other equipment with injury to people and property.

PROPER ELECTRODE LOCATION

Proper location of the electrode assembly is important for optimal system performance. The electrode assembly should be located so that the tips are inside the flame envelope and about 1/2 inch (1.2 cm) above the base of the flame.

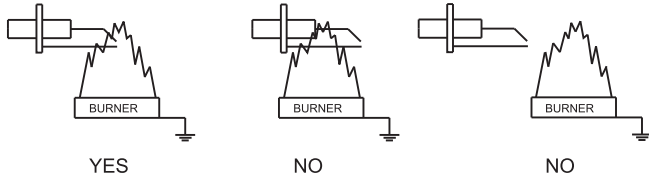

CAUTIONS:

1. Ceramic insulators should not be in or close to the flame.
2. Electrode assemblies should not be adjusted or disassembled. Electrodes should have a gap spacing of 0.125 ± 0.031 inch (3.12 ± 0.81 mm), unless otherwise specified by the appliance manufacturer. If this spacing is not correct, the assembly must be replaced. Electrodes are NOT field-adjustable.
3. Exceeding the temperature limits can cause nuisance lockouts and premature electrode failure.
4. Electrodes must be placed where they are not exposed to the appliance user in normal operation.

TROUBLESHOOTING GUIDE

SYMPTOM	RECOMMENDED ACTIONS
1. Control does not start	A. Miswired B. 24 VAC transformer bad C. Fuse/Circuit breaker bad D. Bad control. Check LED for steady on or flashing code (see Table 1)
2. Thermostat on, no spark	A. Miswired B. Bad thermostat, no voltage at thermostat terminal THS. C. Bad control. Check LED for steady On or flashing codes
3. Valve on, no spark during TFI	A. Shorted electrode - establish 1/8th inch gap B. Check high voltage cable C. Mis-wired
4. Spark on, valve off	A. Valve coil open B. Valve wire disconnected C. Bad control, check voltage at gas valve terminals PV or MV and GND
5. Flame okay during TFI, no flame sense after TFI	A. Check electrode position B. Check high voltage wire C. Poor ground at burner D. Poor flame, check flame current

WIRING DIAGRAMS

LOCAL SENSE

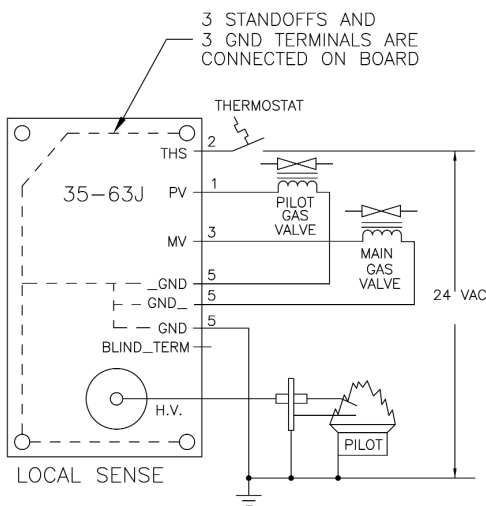

BLIND_TERM: NO CONNECTION TO CONTROL
PLACE HOLDER FOR ANY LOOSE LEAD.

REMOTE SENSE

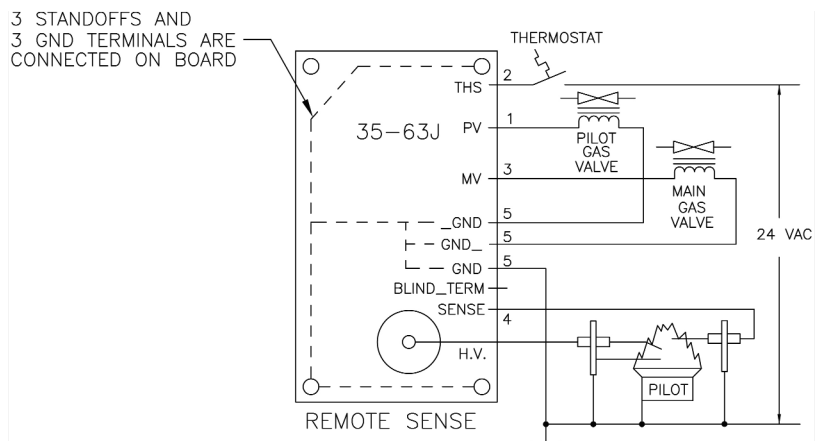

BLIND_TERM: NO CONNECTION TO CONTROL
PLACE HOLDER FOR ANY LOOSE LEAD.

DIMENSIONS

With Cover

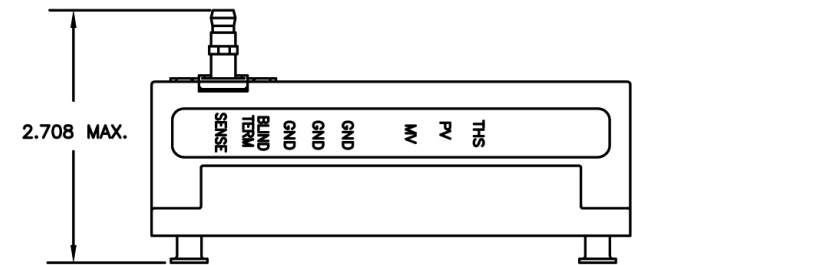
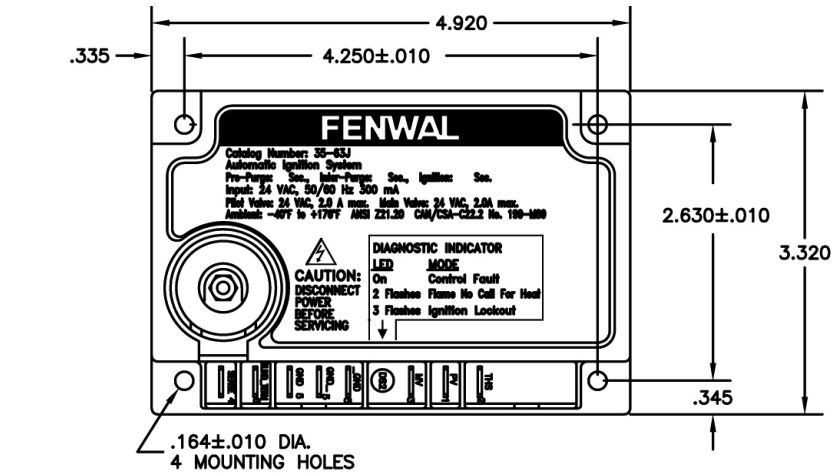

Without Cover

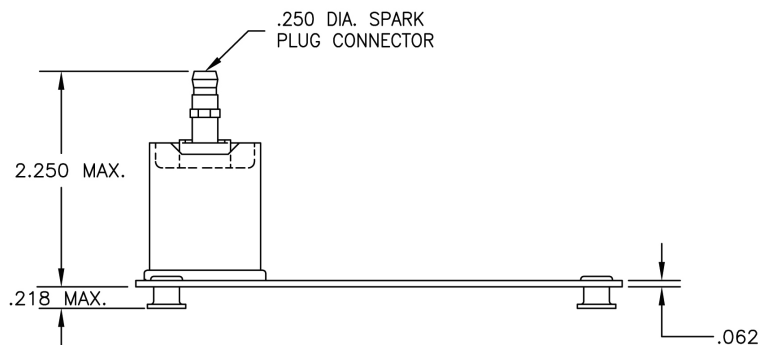
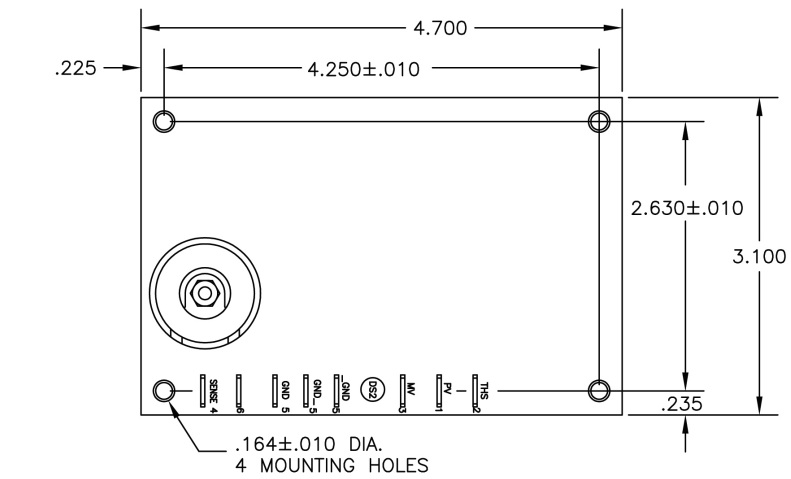

PART NUMBER CONFIGURATION

SERIES 35-63 J X X X -X X X

Options

- 1 = Recycle After Loss of Flame (standard)
- 3 = 1 Hour Auto Reset (in place of 5 minutes)
- 5 = Re-ignition After Flame Loss
- 9 = Special OEM Configuration*

*Non-Standard Configurations

A 9 in this location of the part number (i.e. 35-63 5 901 -113) identifies this configuration as a non-standard design. The part number does not follow the part numbering system. The 9XX is a sequential part number assigned by Fenwal. Consult factory for operating characteristics of this control.

Trial for Ignition

- 1 = 8 Seconds
- 3 = 25 Seconds
- 5 = 50 Seconds
- 7 = 85 Seconds
- 8 = 120 Seconds

Inter-Purge

- 0 = None (Single Try Only)
- 1 = 15 Seconds
- 2 = 30 Seconds
- 3 = 45 Seconds

Pre-Purge

- 0 = None
- 1 = 15 Seconds
- 2 = 30 Seconds
- 4 = 4 Seconds

Tries for Ignition, Flame Sense and Lockout Reset Methods

- | | |
|-------------------------------|------------------------------|
| 0 = Single Try, Local Sense | Thermostat / power off reset |
| 1 = Single Try, Remote Sense | Thermostat / power off reset |
| 2 = Single Try, Local Sense | 5 minute automatic reset |
| 3 = Single Try, Remote Sense | 5 minute automatic reset |
| 5 = Three Tries, Local Sense | Thermostat / power off reset |
| 6 = Three Tries, Remote Sense | Thermostat / power off reset |
| 7 = Three Tries, Local Sense | 5 minute automatic reset |
| 8 = Three Tries, Remote Sense | 5 minute automatic reset |

Enclosure

- 0 = Noryl Gray Enclosure
- 1 = Integral Standoffs
- 2 = Board Only

NOTES:

Maximum Flame Failure Lockout Time = # of Tries x (Inter-Purge + TFI Time)
Maximum Valve Sequence Period = # of Tries x TFI Time

parts4heating
800-536-1582 Fax: 866-448-9304
info@parts4heating.com



FENWAL CONTROLS
400 MAIN STREET, ASHLAND, MA 01721
TEL: (508) 881-2000 FAX: (508) 881-6729
www.fenwalcontrols.com

These instructions do not purport to cover all the details or variations in the equipment described, nor do they provide for every possible contingency to be met in connection with installation, operation and maintenance. All specifications subject to change without notice. Should further information be desired or should particular problems arise which are not covered sufficiently for the purchaser's purposes, the matter should be referred to KIDDE-FENWAL, Inc., Ashland, Massachusetts.