



120 VAC Microprocessor Based Pilot Ignition Control

35.72P

FEATURES

- Continuous ignition whenever flame is not sensed
- Single spark and flame sense
- Main valve energized whenever flame is sensed
- Multi Pin Connector - fast assembly
- Two Mounting Configurations
 - Open Board With Stand-Off's - saves space and cost
 - Potted - protection for washdown and extreme vibration

APPLICATIONS

- Environmentally safe replacement for pilot re-lighter and mercury flame switch systems
- Control of main gas valve in attended or manual pilot ignition systems
- Proof of flame indicators
- Any 120 VAC pilot re-lighter application
- Commercial cooking equipment

DESCRIPTION

The 35-72P is a 120 VAC pilot ignition control for controlling a main gas valve and igniting and monitoring the pilot flame on LP or natural gas heating equipment. The microprocessor-based circuit design provides high energy sparking, dependable flame sensing, and failsafe control of the main gas valve.

It is an ideal "green" solution for replacing pilot re-lighter and mercury flame switch systems in many cooking appliances (see Figure 4 for a typical application wiring diagram). It can also be used for 120VAC pilot re-lighter applications by simply not connecting the main gas valve output.

The 35-72P is also suited for use in specialty applications not requiring direct gas valve control. The V1 output can be used to indicate presence of flame and the 120VAC output level interfaces easily to diagnostic panels or other control systems.

Agency Certifications

Design certified as part of the 35-72 family by CSA International to CAN C22.2 #199-M89 and ANSI Z21.20 for Automatic Ignition Systems.



Replaces Mercury Flame Switch
 + Pilot Re-lighter System

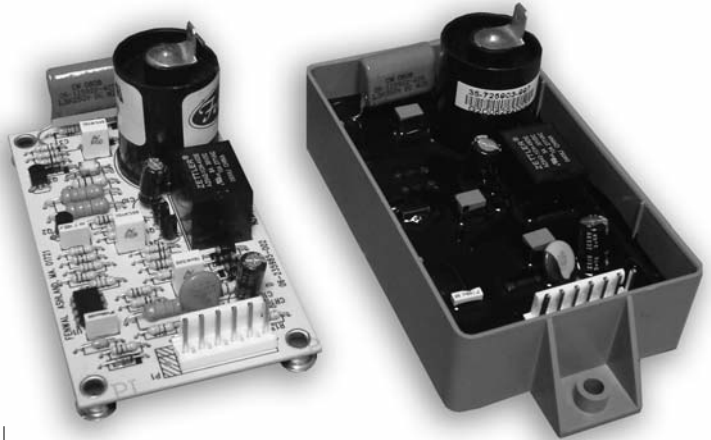

SPECIFICATIONS

Input Power	102 to 138 VAC, 50/60 Hz
Input Current Drain	50mA @ 120 VAC, 60 Hz
Gas Valve Rating	1.5A @ 120 VAC
Operating Temperature	-40°F to +175°F, -40°C to +80°C
Flame Sense Current	1.0 microamp minimum
Flame Failure Response Time	0.8 seconds maximum
Type of Gases	Natural, LP and manufactured
Spark Rate	Line frequency (50/60 Hz)
Moisture Resistance	Conformal coated to operate to 95% R.H. Potted to operate up to 100% R.H.
Size (LxWxH)	See drawing on back page for details
Weight	Integral stand-offs: 2.3 oz Potted: 6.1 oz

PART NUMBERS

PART NUMBER	DESCRIPTION
35-725913-000	Potted
35-725914-000	Open Board with Standoffs

SEQUENCE OF OPERATION

Start up - Normal Operation

Whenever 120 VAC is supplied to the L1 terminal the control will perform a self-check routine and commence sparking until flame is detected.

When flame is detected, the spark is shut off and the main gas valve output is energized. The pilot burner flame is constantly monitored to ensure that the system is functioning properly. When the 120VAC is removed from L1, the gas valve is de-energized immediately and the flame is extinguished.

Failure to Prove Flame

Should the pilot burner fail to light or flame is not detected, the main gas valve remains de-energized and the control continues sparking in attempt to light the pilot.

Flame Failure of Established Flame

If the established flame signal is lost while the burner is operating, the control responds within 0.8 seconds by de-energizing the main gas valve and begins sparking. The sparking will continue until the pilot flame is re-established, at which point sparks will terminate and the main gas valve is energized so that normal main burner operation resumes.

Mounting and Wiring

The 35-72P is not position sensitive and can be mounted vertically or horizontally. The control may be mounted on any surface and fastened with #6 sheet metal screws. Secure the control in an area that will experience a minimum of vibration and remain below the maximum ambient temperature of 80°C (175°F).

All connections should be made with UL approved, 105°C rated, 18 gauge, stranded, thermoplastic insulated wire. Refer to the appropriate wiring diagram when connecting the 35-72P to other components in the system. High voltage spark cables and control wiring harnesses are available.

WARNING: Operation outside specifications could result in failure of the Fenwal product and other equipment with injury or death to people and damage to property.

SINGLE SPARK AND SENSE

Figure 1

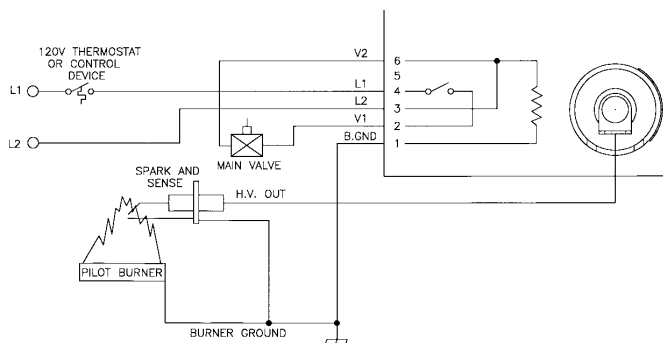

SIX PIN HEADER AMP PART NUMBER 644615-6 ON CIRCUIT BOARD.
SEE PAGES 4 AND 5 FOR MATCHING CONNECTORS AND WIRING HARNESSSES.

TROUBLESHOOTING GUIDE

SYMPTOM	RECOMMENDED ACTIONS
Control will not start up	A. Check wiring B. No voltage @ pin 4, check thermostat C. Check fuse/circuit breaker D. Faulty control, consult Fenwal
No Spark output	A. Shorted electrode - re-establish 1/8" gap B. High voltage cable is disconnected C. Check wiring
Main gas valve remains off after sparks stop	A. Valve coil open B. Valve wire disconnected C. Faulty control, check voltage @ pin 2
Pilot Flame observed but sparks continue (no flame sense)	A. Check electrode position B. Check high voltage wire and connection C. Poor ground @ pin 1 D. Check flame current E. Check for proper L1, L2 polarity

Terminal Designations

TERMINAL	DESCRIPTION	PIN LOCATION	WIRE COLOR
Single Spark and Sense		6-Pin Connector	
B. Gnd	Burner Ground	1	Purple
V1	Valve Power	2	Brown
L2	Line Neutral	3	White
L1	120 VAC Input (Hot)	4	Black
Not Used		5	
V2	Valve Neutral	6	Yellow
HV Transformer	Spark Output	1/4" QC	

CAUTION: Label all wires prior to disconnection when servicing the control. Wiring errors can cause improper and dangerous operation. A functional checkout of a replacement is recommended.

APPLICATION NOTES

Proper Electrode Location

Proper location of the electrode assembly is important for optimum system performance. It is recommended that the electrode assembly be mounted temporarily using clamps or other suitable means to check the system before permanently mounting the assembly. The electrode assembly should be located so that the tips are inside the flame envelope and about 1/2 inch (10 mm) above the base of the flame.

Cautions:

1. Ceramic insulators should not be in or close to the flame.
2. Electrodes should have a gap spacing of 0.125 ± 0.031 inch (3.12 ± 0.81 mm). If this spacing is not correct, the assembly must be replaced.
3. Exceeding the temperature limits can cause nuisance lockouts and premature electrode failure.
4. Electrodes must be placed where they are not exposed to the appliance user in normal operation.

Flame Sensing

Flame sensing is achieved using the principal of flame rectification. Flame rectification relies on current passing from ground through the flame to the sense rod. The minimum flame current necessary to keep the system from lockout is $1.0 \mu\text{A}$.

Figure 2

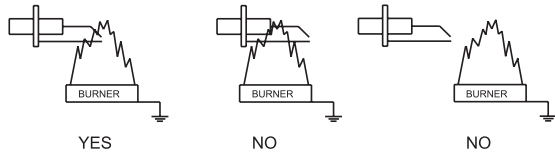

FLAME CURRENT CHECK: SINGLE SPARK & SENSE

To measure flame current, disconnect input voltage, then insert a $0-50 \mu\text{A}$ DC meter and capacitor in series with the spark electrode per Figure 3. Reconnect input voltage and initiate call for heat. After sparking is complete and flame is established meter should read $1.0 \mu\text{A}$ or higher while flame is established. If meter reads below "0" on the scale, meter leads are reversed. Disconnect power and reconnect meter leads for proper polarity.

Figure 3

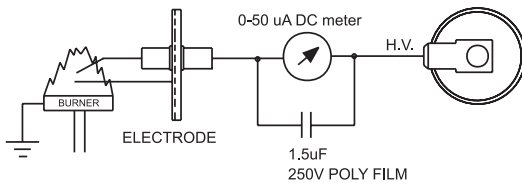

Mercury Flame Switch Replacement

The 35-72P is an ideal replacement for environmentally hazardous Mercury Flame Switch applications. The 35-72 replaces both the pilot re-lighter and flame switch with a single control. In cooking applications the V1 output is energized with 120VAC whenever pilot flame is present allowing the temperature controller to safely cycle the main gas valve as needed.

Figure 4

Mercury Flame Switch Replacement in Cooking Application

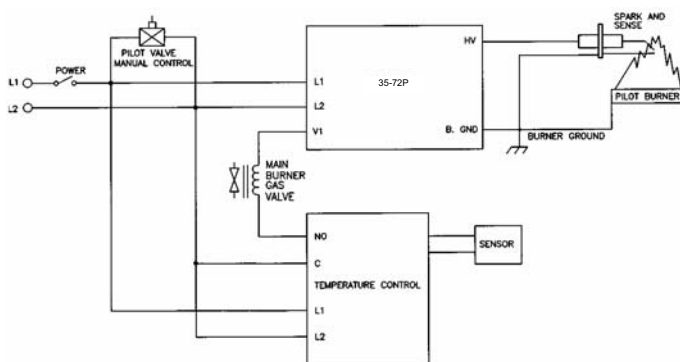

DIMENSIONS

POTTED

Part Number: 35-725913-000

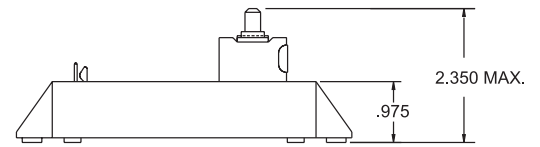
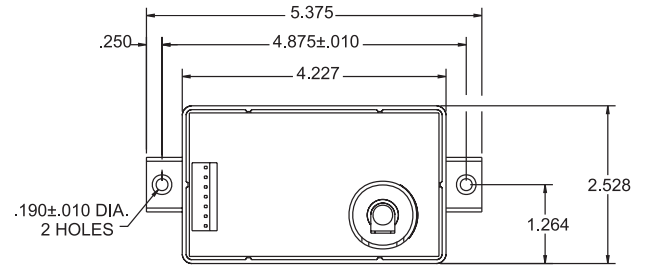

INTEGRAL STAND-OFF

Part Number: 35-725914-000

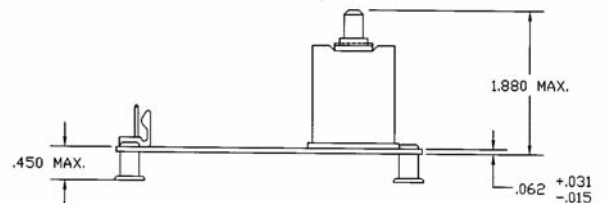
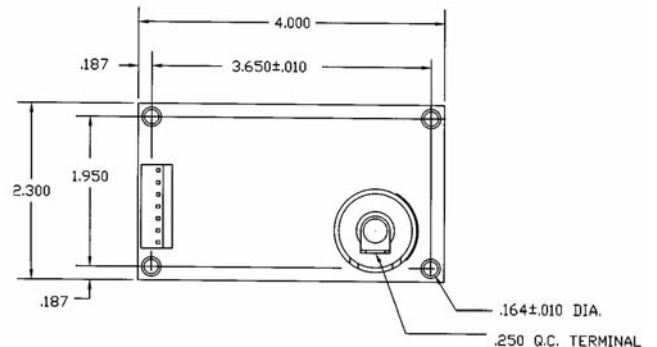

Electrode Assemblies

Providing a variety of spark electrodes and flame sense rods, Fenwal has a design for almost any application. The latest state-of-the-art wire forming and assembly equipment is used to accurately and efficiently produce high quality electrodes that deliver the hottest spark. The "Universal" electrodes depicted below are designed for on-site customization. Cut and bend these to fit your application and then send the formed electrode back for Fenwal to detail **or** send us a print and we will provide you with a quote and samples.

SINGLE SPARK AND SENSE ELECTRODES

Part Number: 22-100001-117

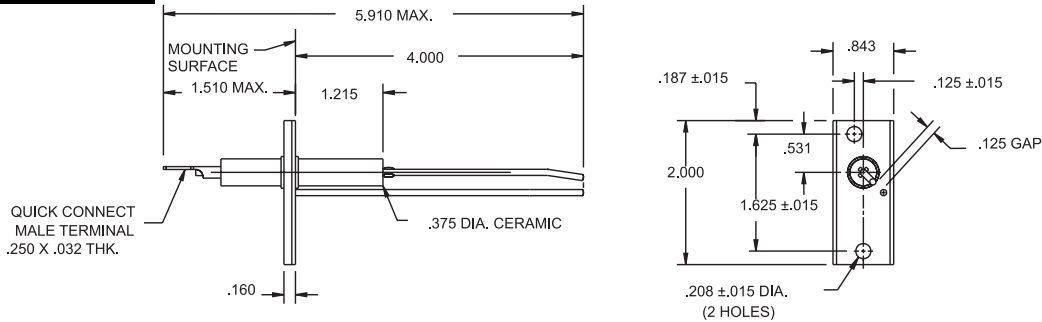

Part Number: 22-100001-052

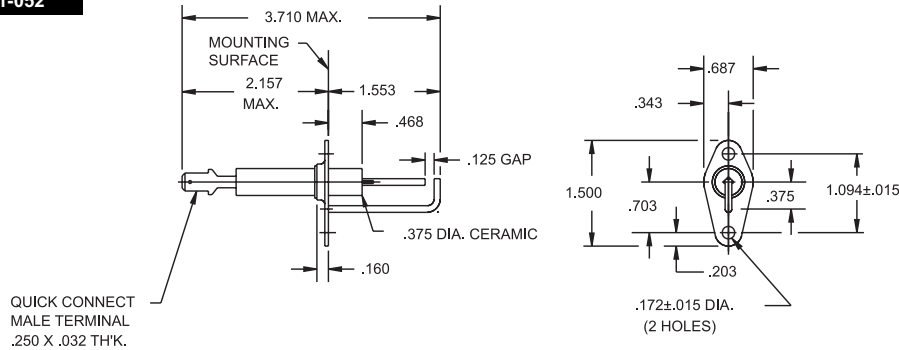

Control Wire Harness

Select a 6 PIN harness for single spark and sense. Once the terminal configuration is determined, complete the part number by replacing the last two digits ("XX") with the length in inches ("L" dimension). Standard wire lengths are 12, 18, 24, 30, 36, 48, and 60 inches. Example: 05-129892-118 = 18 inches. For other lengths, please contact Fenwal.

SPECIFICATIONS:	Voltage Rating	Agency Rating	Temperature Rating	Diameter	Jacket Material
All Wires	600 V	UL/CSA Listed	105°C (221°F)	18 gauge stranded	PVC

SINGLE SPARK AND SENSE

Part Number: 05-129892-0XX

Part Number: 05-129892-1XX

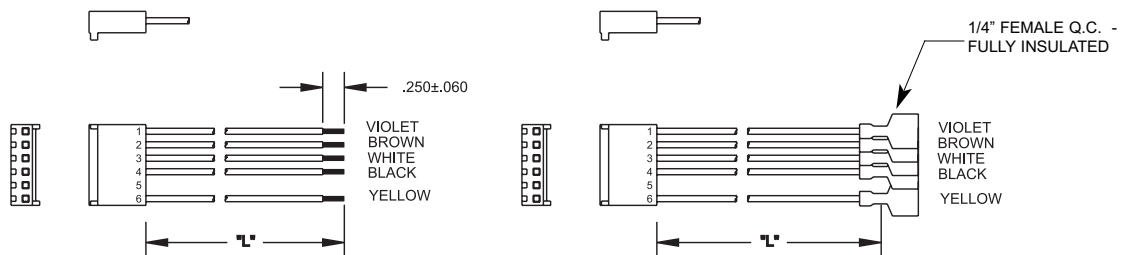

To make your own harness select AMP connector housing P/N: 770849-6 and AMP housing terminal P/N: 770522-1

High Voltage Ignition Wire - 3 Types

Delivering the 15K to 25K volts of spark energy from the ignition control to the electrode is a vital element of an ignition system. There are 3 material options and multiple terminal configurations available. Shown are the most popular versions offered by Fenwal. To ensure maximum spark energy, it is recommended that the ignition wires not be longer than 36". Longer lengths are available and should be evaluated on the appliance to determine if there is sufficient spark energy to consistently light the burner under all conditions. Once the wire type and terminal configurations are determined, complete the part number by replacing the last two digits ("XX") with the length in inches ("L" dimension). Standard wire lengths are 12, 18, 24, 30, 36, 48, and 60 inches. For other lengths, please contact Fenwal.

1. SILICONE RUBBER SUPPRESSION TYPE: Resistive carbon coated fiberglass core prevents spark energy radiation from interfering with other electronic systems. Select this wire type for applications where wire lengths are less than 36" and noise is a major concern.

SPECIFICATIONS:	<u>Voltage Rating</u>	<u>Agency Rating</u>	<u>Temperature Rating</u>	<u>Diameter</u>	<u>Jacket Material</u>
	25 KVDC	SAE J2031	200°C (392°F)	7mm (.27")	Silicone Rubber over Fiberglass Braid

Part Number: 05-129608-0XX

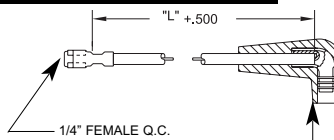

Part Number: 05-129608-2XX

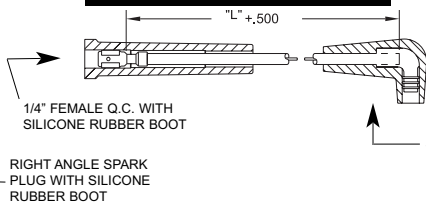

Part Number: 05-129608-6XX

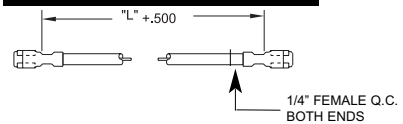

2. SILICONE RUBBER COPPER CONDUCTOR TYPE: Low resistance copper conductor transmits maximum spark energy. Select this type when maximum energy or longer wire lengths are required and noise is not a major concern.

SPECIFICATIONS:	<u>Voltage Rating</u>	<u>Agency Rating</u>	<u>Temperature Rating</u>	<u>Diameter</u>	<u>Jacket Material</u>
	25 KVDC	UL Type 3257	250°C (482°F)	7mm (.27")	Silicone Rubber

Part Number: 05-127613-2XX

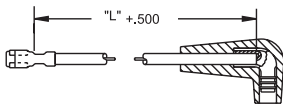

Part Number: 05-129865-0XX

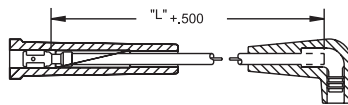

Part Number: 05-125948-0XX

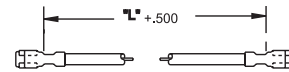

TERMINATIONS SAME AS TYPE 1

3. TEFLON INSULATED TYPE:

Low resistance copper conductor transmits maximum spark energy. Select this type for applications that have tight clearances and sharp bend radii.

SPECIFICATIONS:	<u>Voltage Rating</u>	<u>Agency Rating</u>	<u>Temperature Rating</u>	<u>Diameter</u>	<u>Jacket Material</u>
	25 KVDC	UL Type 1911	250°C (482°F)	2mm (.08")	Teflon

Part Number: 05-129887-0XX

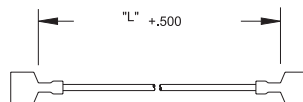

1/4" FEMALE Q.C. - FULLY INSULATED BOTH ENDS

NOTES



Fenwal Controls
400 MAIN STREET, ASHLAND, MA 01721
TEL: (508) 881-2000 FAX: (508) 881-6729
www.fenwalcontrols.com

These instructions do not purport to cover all the details or variations in the equipment described, nor do they provide for every possible contingency to be met in connection with installation, operation and maintenance. All specifications subject to change without notice. Should further information be desired or should particular problems arise which are not covered sufficiently for the purchaser's purposes, the matter should be referred to KIDDE-FENWAL, Inc., Ashland, Massachusetts.